

**AVENTICS** 

**TASKMASTER<sup>®</sup> PNEUMATIC CYLINDERS**  
ALUMINUM NFPA DIMENSIONAL

**Rexroth**  
Pneumatics



# Taskmaster® Pneumatic Cylinder

Design Features, 1-1/2" - 4" Bores



## TaskMaster® Cylinders Index

### Air to 200 psi, 1-1/2" thru 6" Bore

Page

#### 1-1/2" thru 4" Bore

(profile version)

Design Features & Specifications.....	2
Model Codes.....	3
Common Cylinder Model Numbers to Part Numbers.....	4 - 5
MS4 Basic Cylinder Specifications.....	6
Rod Size/Thread Options.....	7
Mounting Styles & Dimensions.....	8 - 15
Accessories.....	16 - 18
Proximity Switch Options.....	19 - 20
Integral Position Sensor (Smart Cylinder).....	21
E/P Positioner.....	21-22
Taskmaster Cylinder/Type 740™ Valve Combination.....	23-24

#### 5" thru 6" Bore

(tie rod version)

Features & Specifications.....	25
How to Order.....	26
Mounting Styles & Dimensions.....	27-32
Accessories.....	33-35

#### Service Information

.....	36-44
-------	-------

#### Pneumatic Timing Volumes

.....	45
-------	----

# Taskmaster® Pneumatic Cylinder

Design Features, 1-1/2" - 4" Bores

## Technical Data, 1-1/2" - 4" bore sizes

### Standard Features include:

Pressure rating: 200 psi air

Temperature range: 0° F to 160° F ambient (for other temperature ranges, contact factory).

Three integral mounts (head, cap and MS4), plus ten additional NFPA mountings available.

Piston Rod: Case hardened to 50-55 Rockwell "C" chrome-plated and finished to 15 micro-inches or better (5/8" not case hardened).

Tube: Hard anodized alloy aluminum for light weight, high strength, & maximum corrosion resistance.

Pre-Lubricated Design: Teflon-coated piston and polyurethane rod seals plus factory pre-lubrication eliminates the need for air line lubrication.

Ports at quadrant 1, cushions at quadrant 2 (both can be ordered in different locations).

Two versions available: TM-1 series is NFPA compliant including rod threads and ports, TM-8 series replaces the original TaskMaster design.

Magnetic piston standard in all cylinders for sensor applications.

Oversize rods available as a standard option.

Stop tubes are available for long stroke, heavy side load applications.

Ports and cushions can be placed in any quadrant for maximum design flexibility.

Smooth head and cap design eliminates gathering of foreign material.

Ports: NPTF dryseal tapered threads, oversize ports available.

Rod End Threads: KK1 male, KK2 male, KK1 female or KK1 studded male threads.

### Teflon Coated Cup Buna "N"

Type, low-friction piston seals are wear-compensating for extended service life.

Non-metallic wear strip provides extended service even under harsh side loads.

Positive rod seal. Pressure energized, polyurethane cup seal is wear compensating for longer life.

Needle valve provides accurate external cushion adjustment.

Long-life rod bearing is corrosion resistant graphite. Operates efficiently even under conditions of marginal lubrication. Rod cartridge can be replaced without cylinder disassembly.

Magnetic piston standard for sensors.

Protective rod wiper increases cylinder life preventing dirt from entering rod gland.

Rugged, non-corroding aluminum tubing is hard anodized for longer cylinder life, and features smooth profile.

Strong, fatigue-resistant rod threads.

High strength steel piston rod. Hard chromium plated for maximum durability. Stainless steel rod available.

Self aligning cushions. Teflon coated floating check valve allows greater cylinder speed.

Smooth, anodized aluminum head and cap design eliminates gathering of foreign material.

(1-1/2" to 4" bore version shown above.)



1-1/2" - 4" Bore Style

5" - 6" Bore Style

Proximity Switch

Cylinder/Valve Combination

Integral Position Sensor

# Taskmaster® Pneumatic Cylinder

Design Features, 1-1/2" - 4" Bores



## Model Code - Taskmaster Cylinders up to 4" Bore

### TaskMaster® Cylinder Model Codes

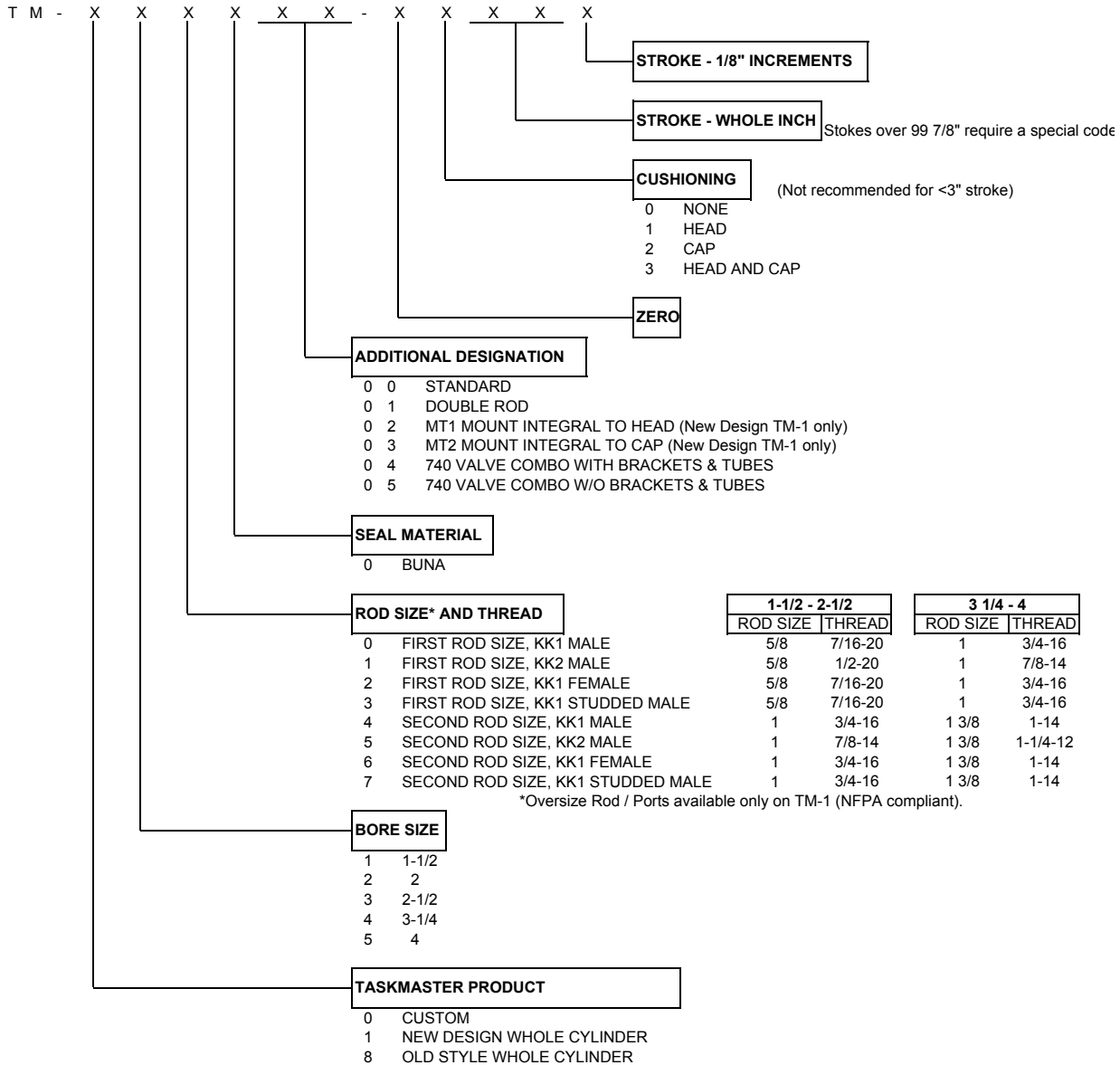

Old custom cylinders converted to new format will be the old part number with the "P" replaced by "TM" model code

Example: P - 0 2 6 4 6 5 - 0 0 0 0 0 will become  
 T M - 0 2 6 4 6 5 - 0 0 0 0 0

Custom cylinders begin with T M - 0 3 1 0 0 0 - X X X X X and proceed sequentially from there.  
 X X X X X is standard suffix format

Customer cylinders are assigned by factory only!

Model code example:

T M - 1 2 0 0 0 0 - 0 3 1 2 5 New design cylinder, 2" bore, first rod size, Buna seals, cushions both ends, 12-5/8" stroke

# Taskmaster® Pneumatic Cylinder

Design Features, 1-1/2" - 4" Bores



## Common MS4 (Basic) Cylinder Part Numbers

Common cylinder model numbers with integral MS4 mount are listed here. For other cylinders, see How to Order section.

The basic TASKMASTER Cylinder is furnished with 3 possible means of mounting: side tapped (MS-4) cap flush, head male rabbet.

Twelve popular mounting kits can be assembled to the basic cylinder and are shown on the following pages.

Mounting kits should be ordered separately from the cylinder.

Mounting kit part numbers and accessory part numbers follow.

For part numbers listed here, rod threads are KK2 male for the TM-8 series. For TM-1 series listed, rod threads are KK1 male. See "How to Order" section for complete breakdown.



1.5" Bore	(original replacement TM-8) Rod thread KK2 = 1/2-20 Port size EE = 1/4" NPTF		(NFPA Compliant TM-1) Rod thread KK1 = 7/16-20 Port size EE = 3/8" NPTF		Description
	Part Number	Model No.	Part Number	Model No.	
	R432021805	TM-811000-00010	R432020388	TM-110000-00010	1.5 X 1 (non-cush)
	R432021812	TM-811000-00020	R432020390	TM-110000-00020	1.5 X 2 (non-cush)
	R432021815	TM-811000-00030	R432020394	TM-110000-00030	1.5 X 3 (non-cush)
	R432021892	TM-811000-03040	R432020418	TM-110000-03040	1.5 X 4 (cushioned)
	R432021895	TM-811000-03050	R432020419	TM-110000-03050	1.5 X 5 (cushioned)
	R432021901	TM-811000-03060	R432020422	TM-110000-03060	1.5 X 6 (cushioned)
	R432021903	TM-811000-03070	R432020424	TM-110000-03070	1.5 X 7 (cushioned)
	R432021906	TM-811000-03080	R432020425	TM-110000-03080	1.5 X 8 (cushioned)
	R432021908	TM-811000-03090	R432020427	TM-110000-03090	1.5 X 9 (cushioned)
	R432021911	TM-811000-03100	R432020429	TM-110000-03100	1.5 X 10 (cushioned)
	R432021917	TM-811000-03120	R432020433	TM-110000-03120	1.5 X 12 (cushioned)
2" Bore	(original replacement TM-8) Rod thread KK2 = 1/2-20 Port size EE = 1/4" NPTF		(NFPA Compliant TM-1) Rod thread KK1 = 7/16-20 Port size EE = 3/8" NPTF		Description
	Part Number	Model No.	Part Number	Model No.	
	R432022232	TM-821000-00010	R432020604	TM-120000-00010	2 X 1 (non-cush)
	R432022237	TM-821000-00020	R432020606	TM-120000-00020	2 X 2 (non-cush)
	R432022240	TM-821000-00030	R432020610	TM-120000-00030	2 X 3 (non-cush)
	R432022318	TM-821000-03040	R432020636	TM-120000-03040	2 X 4 (cushioned)
	R432022323	TM-821000-03050	R432020638	TM-120000-03050	2 X 5 (cushioned)
	R432022327	TM-821000-03060	R432020640	TM-120000-03060	2 X 6 (cushioned)
	R432022331	TM-821000-03070	R432020641	TM-120000-03070	2 X 7 (cushioned)
	R432022332	TM-821000-03080	R432020643	TM-120000-03080	2 X 8 (cushioned)
	R432022335	TM-821000-03090	R432020644	TM-120000-03090	2 X 9 (cushioned)
	R432022337	TM-821000-03100	R432020645	TM-120000-03100	2 X 10 (cushioned)
	R432022341	TM-821000-03120	R432020647	TM-120000-03120	2 X 12 (cushioned)

# Taskmaster® Pneumatic Cylinder

Design Features, 1-1/2" - 4" Bores



2.5" Bore	(original replacement TM-8) Rod thread KK2 = 1/2-20 Port size EE = 1/4" NPTF		(NFPA Compliant TM-1) Rod thread KK1 = 7/16-20 Port size EE = 3/8" NPTF		Description
	Part Number	Model No.	Part Number	Model No.	
	R432022613	TM-831000-00010	R432020859	TM-130000-00010	2.5 X 1 (non-cush)
	R432022619	TM-831000-00020	R432020861	TM-130000-00020	2.5 X 2 (non-cush)
	R432022625	TM-831000-00030	R432020863	TM-130000-00030	2.5 X 3 (non-cush)
	R432022686	TM-831000-03040	R432020890	TM-130000-03040	2.5 X 4 (cushioned)
	R432022689	TM-831000-03050	R432020892	TM-130000-03050	2.5 X 5 (cushioned)
	R432022691	TM-831000-03060	R432020893	TM-130000-03060	2.5 X 6 (cushioned)
	R432022696	TM-831000-03070	R432020894	TM-130000-03070	2.5 X 7 (cushioned)
	R432022699	TM-831000-03080	R432020895	TM-130000-03080	2.5 X 8 (cushioned)
	R432022702	TM-831000-03090	R432020897	TM-130000-03090	2.5 X 9 (cushioned)
	R432022703	TM-831000-03100	R432020898	TM-130000-03100	2.5 X 10 (cushioned)
	R432022708	TM-831000-03120	R432020900	TM-130000-03120	2.5 X 12 (cushioned)
3.25" Bore	(original replacement TM-8) Rod thread KK2 = 7/8-14 Port size EE = 3/8" NPTF		(NFPA Compliant TM-1) Rod thread KK1 = 3/4-16 Port size EE = 1/2" NPTF		Description
	Part Number	Model No.	Part Number	Model No.	
	R432022902	TM-841000-00010	R432021102	TM-140000-00010	3.25 X 1 (non-cush)
	R432022906	TM-841000-00020	R432021104	TM-140000-00020	3.25 X 2 (non-cush)
	R432022910	TM-841000-00030	R432021106	TM-140000-00030	3.25 X 3 (non-cush)
	R432022973	TM-841000-03040	R432021143	TM-140000-03040	3.25 X 4 (cushioned)
	R432022978	TM-841000-03050	R432021145	TM-140000-03050	3.25 X 5 (cushioned)
	R432022981	TM-841000-03060	R432021148	TM-140000-03060	3.25 X 6 (cushioned)
	R432022985	TM-841000-03070	R432021149	TM-140000-03070	3.25 X 7 (cushioned)
	R432022989	TM-841000-03080	R432021150	TM-140000-03080	3.25 X 8 (cushioned)
	R432022992	TM-841000-03090	R432021151	TM-140000-03090	3.25 X 9 (cushioned)
	R432022994	TM-841000-03100	R432021153	TM-140000-03100	3.25 X 10 (cushioned)
	R432023002	TM-841000-03120	R432021155	TM-140000-03120	3.25 X 12 (cushioned)
4" Bore	(original replacement TM-8) Rod thread KK2 = 7/8-14 Port size EE = 3/8" NPTF		(NFPA Compliant TM-1) Rod thread KK1 = 3/4-16 Port size EE = 1/2" NPTF		Description
	Part Number	Model No.	Part Number	Model No.	
	R432023256	TM-851000-00010	R432021306	TM-150000-00010	4 X 1 (non-cush)
	R432023258	TM-851000-00020	R432021308	TM-150000-00020	4 X 2 (non-cush)
	R432023260	TM-851000-00030	R432021312	TM-150000-00030	4 X 3 (non-cush)
	R432023314	TM-851000-03040	R432021339	TM-150000-03040	4 X 4 (cushioned)
	R432023317	TM-851000-03050	R432021340	TM-150000-03050	4 X 5 (cushioned)
	R432023320	TM-851000-03060	R432021341	TM-150000-03060	4 X 6 (cushioned)
	R432023322	TM-851000-03070	R432021342	TM-150000-03070	4 X 7 (cushioned)
	R432023325	TM-851000-03080	R432021343	TM-150000-03080	4 X 8 (cushioned)
	R432023328	TM-851000-03090	R432021344	TM-150000-03090	4 X 9 (cushioned)
	R432023331	TM-851000-03100	R432021346	TM-150000-03100	4 X 10 (cushioned)
	R432023336	TM-851000-03120	R432021347	TM-150000-03120	4 X 12 (cushioned)

MODEL NUMBER CONVERSION

Bore	Current Versions				
	1960's	1970's	1980's-90's	TM-8 Series	TM-1 Series
1 1/2"	P -057270-	P -060162-	P -068174-	TM-811000-	TM-110000-
2"	P -057196-	P -060170-	P -068177-	TM-821000-	TM-120000-
2 1/2"	P -057284-	P -060179-	P -068180-	TM-831000-	TM-130000-
3 1/4"	P -057297-	P -060188-	P -068183-	TM-841000-	TM-140000-
4"	P -057527-	P -060197-	P -068186-	TM-851000-	TM-150000-

# Taskmaster® Pneumatic Cylinder

## MS4 Basic Cylinder Specifications



### MS4 [BASIC CYLINDER]

### Side Tapped Mounting

#### MS4

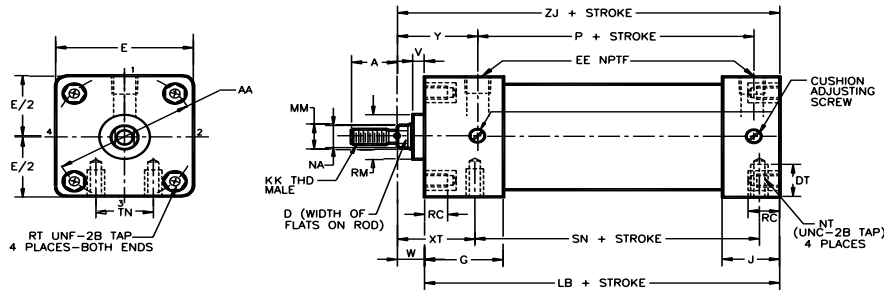

BASIC CYLINDER - MODULAR DESIGN. Refer to these tables for dimensions not shown on other mounts, or for those affected by rod size. All dimensions are in inches unless otherwise indicated.

TaskMaster basic cylinder is furnished with 3 possible mounts: MS4 side-tapped mount, cap flush, or head male rabbet.

Twelve popular mounting kits can be assembled to the basic cylinder and are detailed in the following sections.

Mounting kits should be ordered separately from the cylinder; for basic cylinder part numbers, see "How to Order" section or Common Cylinder Part Numbers section.

MS4 Table 1. Dimensions affected by rod diameter. (Dimensions in inches)

BORE SIZE	MM ROD	W [TM-8]	W [TM-1]	EE [TM-8]	EE [TM-1]	RM	DT (cap)	DT (head)	ZJ [TM-8]	ZJ [TM-1]	A [TM-8]	A [TM-1]	D	NA
1.50	0.625	0.59	0.62	1/4	3/8	1.12	0.38	0.38	4.63	4.66	1.00	0.75	0.50	0.56
1.50	1.000	-	1.00	-	3/8	1.50	0.38	0.25	-	5.04	-	1.12	0.88	0.94
2.00	0.625	0.59	0.62	1/4	3/8	1.12	0.50	0.50	4.63	4.66	1.00	0.75	0.50	0.56
2.00	1.000	-	1.00	-	3/8	1.50	0.50	0.38	-	5.04	-	1.12	0.88	0.94
2.50	0.625	0.59	0.62	1/4	3/8	1.12	0.69	0.69	4.75	4.78	1.00	0.75	0.50	0.56
2.50	1.000	-	1.00	-	3/8	1.50	0.69	0.50	-	5.16	-	1.12	0.88	0.94
3.25	1.000	0.75	0.75	3/8	1/2	1.50	0.75	0.75	5.63	5.63	1.50	1.12	0.88	0.94
3.25	1.375	-	1.00	-	1/2	2.38	0.75	0.75	-	5.88	-	1.63	1.12	1.31
4.00	1.000	0.75	0.75	3/8	1/2	1.50	0.75	0.75	5.63	5.63	1.50	1.12	0.88	0.94
4.00	1.375	-	1.00	-	1/2	2.38	0.75	0.75	-	5.88	-	1.63	1.12	1.31

Oversize rods and ports are not available for TM-8 series.

MS4 Table 1. (cont.) Dimensions affected by rod diameter.

BORE SIZE	MM ROD	Y [TM-8]	Y [TM-1]	XT [TM-8]	XT [TM-1]
1.50	0.625	1.75	1.79	1.94	1.98
1.50	1.000	-	2.16	-	2.35
2.00	0.625	1.75	1.79	1.94	1.98
2.00	1.000	-	2.16	-	2.35
2.50	0.625	1.75	1.79	1.94	1.98
2.50	1.000	-	2.16	-	2.35
3.25	1.000	2.34	2.39	2.44	2.45
3.25	1.375	-	2.64	-	2.70
4.00	1.000	2.34	2.39	2.44	2.45
4.00	1.375	-	2.64	-	2.70

MS4 Table 2. Dimensions not affected by rod diameter.

BORE SIZE	E	G	J	P	V	AA	LB	NT	RC	RT	SN	TN
1.50	2.00	1.72	1.12	2.31	0.25	2.02	4.03	1/4-20	0.47	1/4-28	2.25	0.62
2.00	2.50	1.72	1.12	2.31	0.25	2.60	4.03	5/16-18	0.50	5/16-24	2.25	0.88
2.50	3.00	1.72	1.25	2.44	0.25	3.10	4.16	3/8-16	0.50	5/16-24	2.38	1.25
3.25	3.75	2.25	1.12	2.75	0.25	3.90	4.88	1/2-13	0.53	3/8-24	2.62	1.50
4.00	4.50	2.25	1.12	2.69	0.25	4.70	4.88	1/2-13	0.53	3/8-24	2.62	2.06

\*For 1.375" rod, P = 2.84.

# Taskmaster® Pneumatic Cylinder

MS4 Basic Cylinder Specifications



## Rod Size/Thread Options

### TASKMASTER ROD THREAD OPTIONS

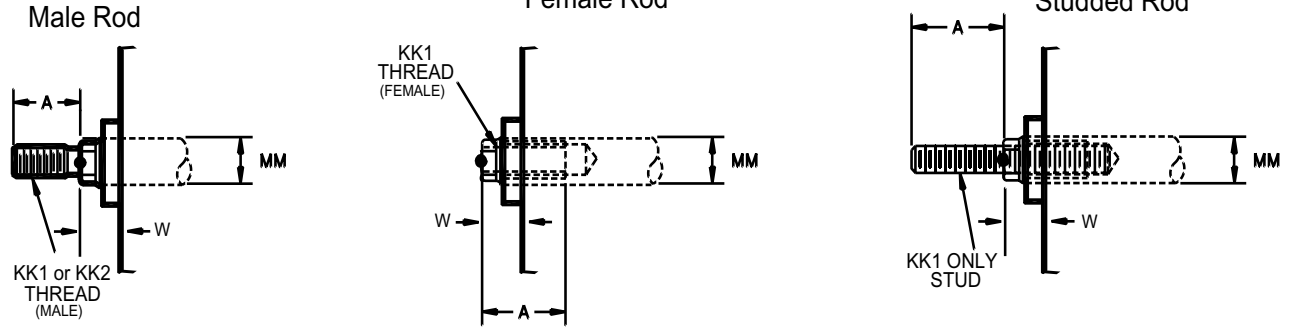

Rod thread options						TM-8		TM-1	
Bore size	MM Rod	Male KK2	Female KK1	Male KK1	Stud KK1	A	W	A	W
1-1/2, 2, 2-1/2"	0.625	1/2-20	7/16-20	7/16-20	7/16-20	1.00	0.59	0.75	0.62
1-1/2, 2, 2-1/2"	1.000	7/8-14	3/4-16	3/4-16	3/4-16	–	–	1.12	1.00
3-1/4, 4"	1.000	7/8-14	3/4-16	3/4-16	3/4-16	1.50	0.75	1.12	0.75
3-1/4, 4"	1.380	1-1/4-12	1-14	1-14	1-14	–	–	1.63	1.00

Male threads available in KK1 and KK2 thread sizes.

Female threads available in KK1 thread only. KK1 studded male rod end available.

Note: Oversize rods were not available on earlier models, therefore not available on TM-8 series.



# Taskmaster® Pneumatic Cylinder

MF1 Flange Mounting Kits - 1.5" thru 4" bore



## MF1 Flange Mounting Kit (Aluminum)

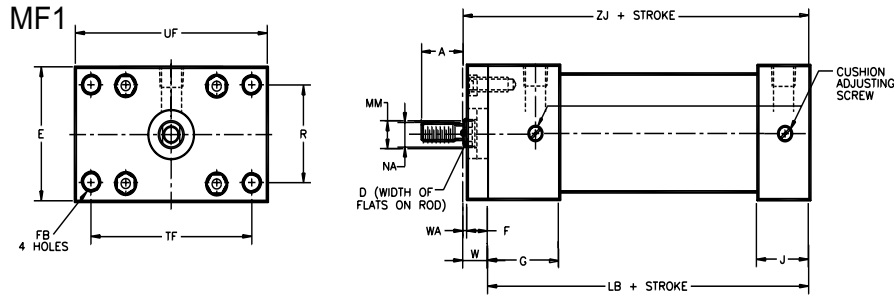

Part Number	MF1												
KIT PART NUMBER	BORE SIZE	MM ROD	E	F	R	W*	FB	LB	TF	UF	WA*	ZJ*	WEIGHT
R432013373	1.500	0.625	2.00	0.38	1.43	0.59	0.34	4.03	2.75	3.38	0.22	4.63	0 lb. 4 oz.
R432012520	2.000	0.625	2.50	0.50	1.84	0.59	0.41	4.03	3.38	4.13	0.09	4.63	0 lb. 8 oz.
R432013382	2.500	0.625	3.00	0.50	2.19	0.59	0.41	4.16	3.88	4.63	0.09	4.75	0 lb. 12 oz.
R432013388	3.250	1.000	3.50**	0.63	2.76	0.75	0.47	4.88	4.69	5.50	0.13	5.63	1 lb. 4 oz.
R432013396	4.000	1.000	4.50	0.63	3.32	0.75	0.47	4.88	5.44	6.25	0.13	5.63	1 lb. 12 oz.

Mounting kit only, order cylinder separately. These kits fit first and second rod sizes. Dimensions in inches, for those not shown see MS4 basic cylinder drawing.

\*Dimensions are for TM-8 series, for TM-1 series see MS4 basic cylinder drawing.

\*\*Dimension not NFPA standard, and differs from E dimension on cylinder, see basic MS4 cylinder drawing.

## MF2 Flange Mounting Kit (Aluminum)

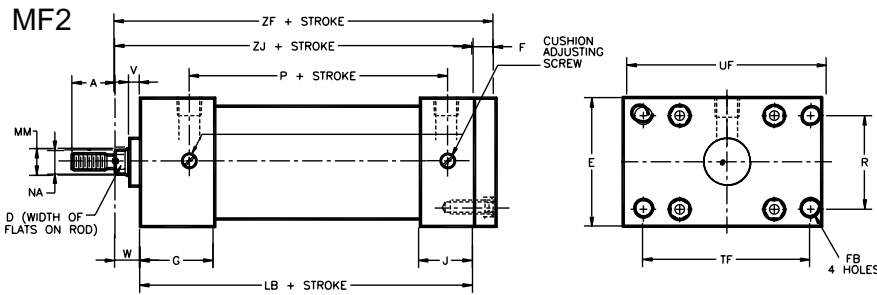

Model	MF2												
KIT PART NUMBER	BORE SIZE	MM ROD	E	F	R	W*	FB	LB	TF	UF	ZF*	ZJ*	WEIGHT
R432013373	1.500	0.625	2.00	0.38	1.43	0.59	0.34	4.03	2.75	3.38	5.00	4.63	0 lb. 4 oz.
R432012520	2.000	0.625	2.50	0.50	1.84	0.59	0.41	4.03	3.38	4.13	5.13	4.63	0 lb. 8 oz.
R432013382	2.500	0.625	3.00	0.50	2.19	0.59	0.41	4.16	3.88	4.63	5.25	4.75	0 lb. 12 oz.
R432013388	3.250	1.000	3.50**	0.63	1.76	0.75	0.47	4.88	4.69	5.50	6.25	5.63	1 lb. 4 oz.
R432013396	4.000	1.000	4.50	0.63	3.32	0.75	0.47	4.88	5.44	6.25	6.25	5.63	1 lb. 12 oz.

Mounting kit only, order cylinder separately. These kits fit first and second rod sizes. Dimensions in inches, for those not shown see MS4 basic cylinder drawing.

\*Dimensions are for TM-8 series, for TM-1 series see MS4 basic cylinder drawing.

\*\*Dimension not NFPA standard, and differs from E dimension on cylinder, see basic MS4 cylinder drawing.

# Taskmaster® Pneumatic Cylinder

MP1 Clevis Mounting Kits - 1.5" thru 4" bore



## MP1 Clevis Mounting Kit (Cast Iron), includes pivot pin

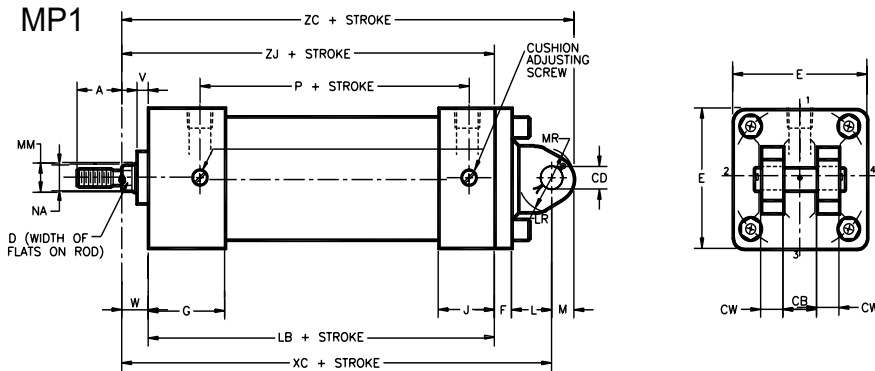

Model	MP1															
KIT PART NUMBER	BORE SIZE	MM ROD	E	F	L	W*	CB	CD	CW	LB	LR	MR	XC*	ZC*	ZJ*	WEIGHT
R432015731	1.500	0.625	2.00	0.38	0.38	0.59	0.75	0.500	0.50	4.03	0.75	0.63	5.38	5.88	4.63	0 lb. 6 oz.
R432015733	2.000	0.625	2.50	0.38	0.38	0.59	0.75	0.500	0.50	4.03	0.75	0.63	5.38	5.88	4.63	1 lb. 0 oz.
R432015735	2.500	0.625	3.00	0.38	0.38	0.59	0.75	0.500	0.50	4.16	0.75	0.63	5.50	6.00	4.75	1 lb. 4 oz.
R432015737	3.250	1.000	3.75	0.63	0.63	0.75	1.25	0.750	0.63	4.88	1.25	0.88	6.88	7.63	5.63	2 lb. 8 oz.
R432015739	4.000	1.000	4.50	0.63	0.63	0.75	1.25	0.750	0.63	4.88	1.25	0.88	6.88	7.63	5.63	3 lb. 8 oz.

Mounting kit only, order cylinder separately. These kits are not affected by rod size. Dimensions in inches, for those not shown see MS4 basic cylinder drawing.

\*Dimensions are for TM-8 series, for TM-1 series see MS4 basic cylinder drawing.

## MP2 Clevis Mounting Kit (Aluminum and Steel), includes pivot pin

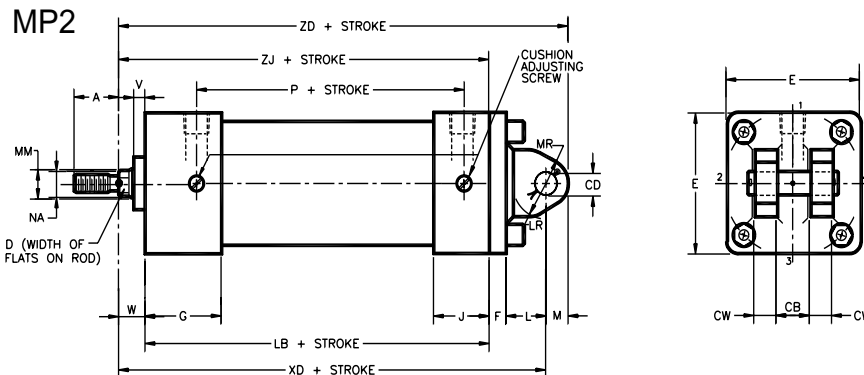

Model	MP2																
BORE SIZE/ (Kit Material)	KIT PART NUMBER	WEIGHT	MM ROD	E	F	L	M	W*	CB	CD	CW	LB	LR	MR	XD*	ZD*	ZJ*
1.5 (Alum.)	R432013371	0 lb. 8 oz.	0.625	2.00	0.38	0.75	0.50	0.59	0.75	0.500	0.50	4.03	0.63	0.53	5.75	6.25	4.63
1.5 (Steel)	R432008309	0 lb. 14 oz.	0.625	2.00	0.38	0.75	0.50	0.59	0.75	0.500	0.50	4.03	0.59	0.69	5.75	6.25	4.63
2.0 (Alum.)	R432012512	0 lb. 8 oz.	0.625	2.50	0.38	0.75	0.50	0.59	0.75	0.500	0.50	4.03	0.63	0.53	5.75	6.25	4.63
2.0 (Steel)	R432008305	1 lb. 4 oz.	0.625	2.50	0.38	0.75	0.50	0.59	0.75	0.500	0.50	4.03	0.59	0.69	5.75	6.25	4.63
2.5 (Alum.)	R432013379	0 lb. 12 oz.	0.625	3.00	0.38	0.75	0.50	0.59	0.75	0.500	0.50	4.16	0.63	0.53	5.88	6.38	4.75
2.5 (Steel)	R432008306	1 lb. 8 oz.	0.625	3.00	0.38	0.75	0.50	0.59	0.75	0.500	0.50	4.16	0.59	0.69	5.88	6.38	4.75
3.25 (Alum.)	R432013394	1 lb. 12 oz.	1.000	3.75	0.56	1.31	0.75	0.75	1.25	0.750	0.63	4.88	0.88	0.88	7.50	8.25	5.63
3.25 (Steel)	R432008307	3 lb. 12 oz.	1.000	3.75	0.63	1.25	0.75	0.75	1.25	0.750	0.63	4.88	0.88	1.00	7.50	8.25	5.63
4.0 (Alum.)	R432013402	2 lb. 4 oz.	1.000	4.50	0.63	1.25	0.75	0.75	1.25	0.750	0.63	4.88	0.88	0.78	7.50	8.25	5.63
4.0 (Steel)	R432008308	4 lb. 12 oz.	1.00	4.50	0.63	1.25	0.75	0.75	1.25	0.750	0.63	4.88	0.88	1.00	7.50	8.25	5.63

Mounting kit only, order cylinder separately. These kits are not affected by rod size. Dimensions in inches, for those not shown see MS4 basic cylinder drawing.

\*Dimensions are for TM-8 series, for TM-1 series see MS4 basic cylinder drawing.

# Taskmaster® Pneumatic Cylinder

MP4 Mounting Kits - 1.5" thru 4" bore



## MP4 Eye Bracket Mounting Kit (Aluminum)

MP4

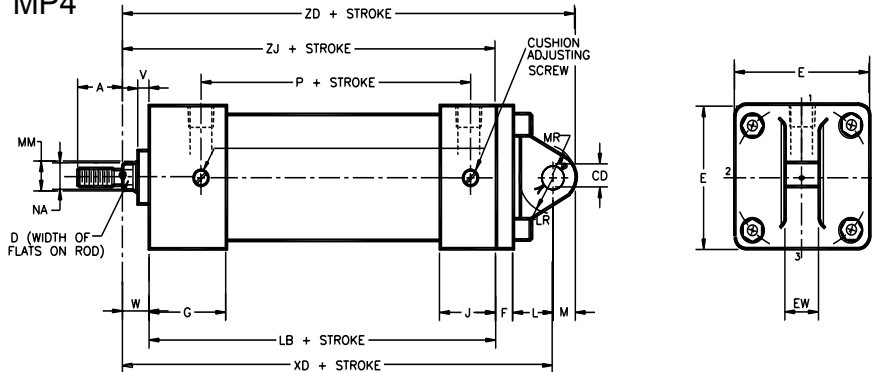

Model	MP4															
KIT PART NUMBER	BORE SIZE	MM ROD	E	F	L	M	W*	CD	EW	LB	LR	MR	XD*	ZD*	ZJ*	WEIGHT
R432013369	1.500	0.625	2.00	0.38	0.75	0.50	0.59	0.500	0.75	4.03	0.63	0.53	5.75	6.25	4.63	0 lb. 8 oz.
R432012549	2.000	0.625	2.50	0.38	0.75	0.50	0.59	0.500	0.75	4.03	0.63	0.53	5.75	6.25	4.63	0 lb. 8 oz.
R432013377	2.500	0.625	3.00	0.38	0.75	0.50	0.59	0.500	0.75	4.16	0.63	0.53	5.88	6.38	4.75	0 lb. 9 oz.
R432013392	3.250	1.000	3.75	0.63	1.25	0.75	0.75	0.750	1.25	4.88	0.88	0.78	7.50	8.25	5.63	1 lb. 7 oz.
R432013400	4.000	1.000	4.50	0.63	1.25	0.75	0.75	0.750	1.25	4.88	0.88	0.78	7.50	8.25	5.63	1 lb. 12oz.

Mounting kit only, order cylinder separately. These kits are not affected by rod size. Dimensions in inches, for those not shown see MS4 basic cylinder drawing.

\*Dimensions are for TM-8 series, for TM-1 series see MS4 basic cylinder drawing.

## MS1 Mounting Kit (steel)

MS1

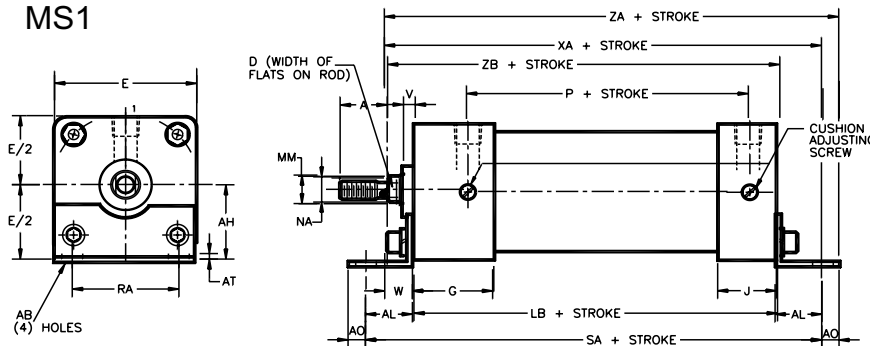

Model	MS1																	
BORE SIZE	KIT PART NUMBER	WEIGHT	MM ROD	E	W*	AB	AH	AL	AO	AT	DD	LB	RA	SA	XA*	ZA*	ZB*	
1.500	R432013623	0 lb. 6 oz.	0.625	2.00	0.59	0.44	1.19	1.00	0.37	0.12	1/4-28	4.03	1.25	6.03	5.63	6.00	4.63	
2.000	R432013625	0 lb. 8 oz.	0.625	2.50	0.59	0.44	1.44	1.00	0.37	0.12	5/16-24	4.03	1.75	6.03	5.63	6.00	4.63	
2.500	R432013628	0 lb. 9 oz.	0.625	3.00	0.59	0.44	1.62	1.00	0.37	0.12	5/16-24	4.16	2.25	6.16	5.75	6.13	4.75	
3.250	R432013631	0 lb. 14 oz.	1.000	3.75	0.75	0.56	1.94	1.25	0.50	0.12	3/8-24	4.88	2.75	7.38	6.88	7.38	5.63	
4.000	R432013634	1 lb. 0 oz.	1.000	4.50	0.75	0.56	2.25	1.25	0.50	0.12	3/8-24	4.88	3.50	7.38	6.88	7.38	5.63	

Mounting kit only, order cylinder separately. These kits fit first and second rod sizes. Dimensions in inches, for those not shown see MS4 basic cylinder drawing.

\*Dimensions are for TM-8 series, for TM-1 series see MS4 basic cylinder drawing.

# Taskmaster® Pneumatic Cylinder

MS2 Mounting Kits - 1.5" thru 4" bore



## MS2 Mounting Kit (Steel) 1 1/2" - 2 1/2" Bore

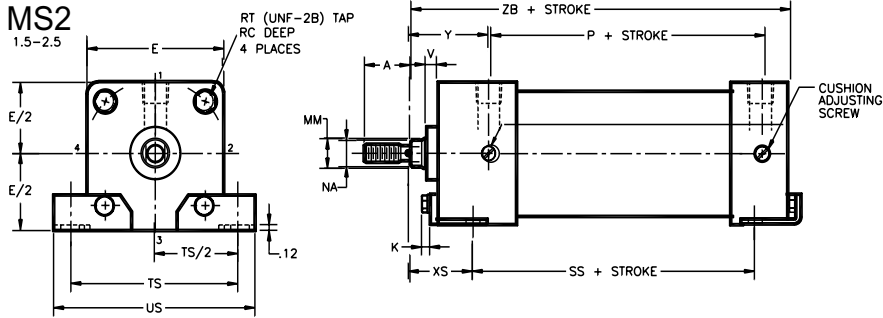

Model	MS2																	
KIT PART NUMBER	WEIGHT	BORE SIZE	MM ROD	C	F	K	W*	SB	SS	ST	SU	SW	SY	SZ	TS	US	XS*	ZB*
R432013616	0 lb. 6 oz.	1.500	0.625	0.75	2.00	0.23	0.59	0.44	2.88	0.12	0.48	0.88	0.90	0.50	2.75	3.43	1.38	4.62
R432013641	0 lb. 6 oz.	2.000	0.625	0.75	2.50	0.28	0.59	0.44	2.88	0.12	0.48	0.88	0.90	0.50	3.32	4.08	1.38	4.62
R432013641	0 lb. 6 oz.	2.500	0.625	0.75	3.00	0.28	0.59	0.44	3.00	0.12	0.48	0.88	0.90	0.50	3.67	4.43	1.38	4.75

Mounting kit only, order cylinder separately. These kits fit first and second rod sizes. Dimensions in inches, for those not shown see MS4 basic cylinder drawing.

\*Dimensions are for TM-8 series, for TM-1 series see MS4 basic cylinder drawing.

## MS2 Mounting Kit (Steel) 3 1/4" - 4" Bore

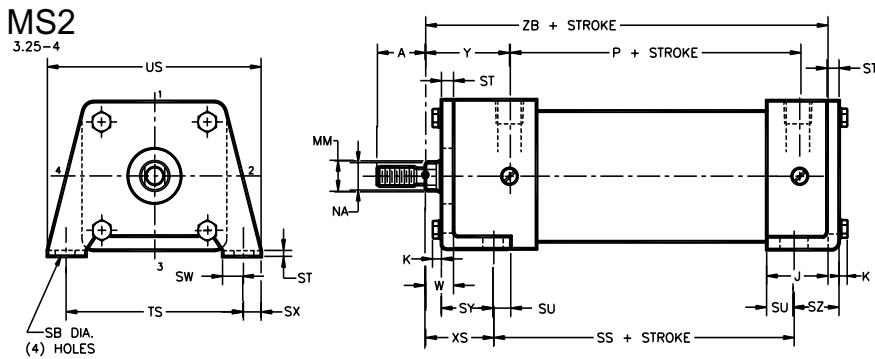

Model	MS2																	
KIT PART NUMBER	WEIGHT	BORE SIZE	MM ROD	E	K	W*	SB	SS	ST	SU	SW	SX	SY	SZ	TS	US	XS*	ZB*
R432013648	2 lb. 12 oz.	3.250	1.000	3.75	0.34	0.75	0.56	3.25	0.25	0.62	0.50	0.50	1.38	0.75	4.75	5.75	1.88	5.62
R432013651	4 lb. 4 oz.	4.000	1.000	4.50	0.34	0.75	0.56	3.25	0.31	0.62	0.50	0.50	1.44	0.81	5.50	6.50	1.88	5.62

Mounting kit only, order cylinder separately. These kits fit first and second rod sizes. Dimensions in inches, for those not shown see MS4 basic cylinder drawing.

\*Dimensions are for TM-8 series, for TM-1 series see MS4 basic cylinder drawing.

# Taskmaster® Pneumatic Cylinder

MT1 Mounts - 1.5" thru 4" bore



## MT1 Front Trunnion<sup>1</sup> Mount - TM-1 Series [NFPA compliant] Complete Cylinder Dimensions

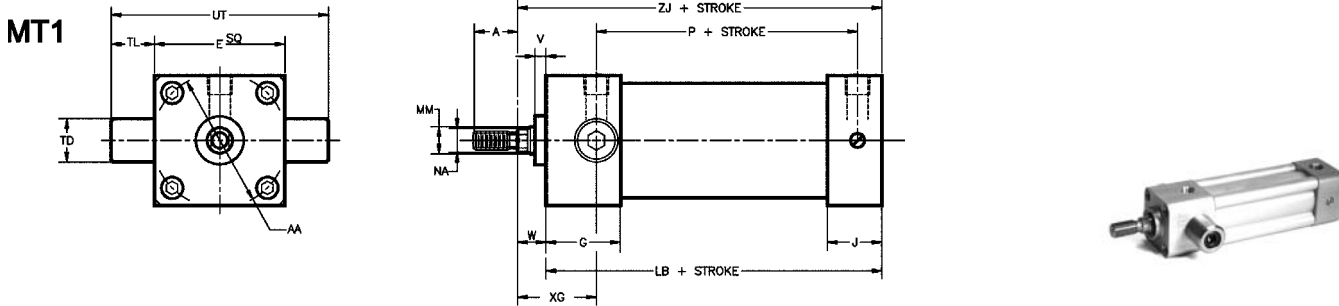

MT1 [TM-1 Series Complete Cylinder Dimensions]											
BORE SIZE	MM ROD	E	W	AA	LB	TD	TL	UT	XG	ZJ	WEIGHT
1.500	0.625	2.00	0.63	2.02	4.03	1.00	1.00	4.00	1.75	4.66	2 lb. 2 oz.
1.500	1.000	2.00	1.00	2.02	4.03	1.00	1.00	4.00	2.12	5.04	2 lb. 12 oz.
2.000	0.625	2.50	0.63	2.60	4.03	1.00	1.00	4.50	1.75	4.66	2 lb. 15 oz.
2.000	1.000	2.50	1.00	2.60	4.03	1.00	1.00	4.50	2.12	5.04	3 lb. 9 oz.
2.500	0.625	3.00	0.63	3.10	4.16	1.00	1.00	5.00	1.75	4.78	3 lb. 0 oz.
2.500	1.000	3.00	1.00	3.10	4.16	1.00	1.00	5.00	2.12	5.16	3 lb. 10 oz.
3.250	1.000	3.75	0.75	3.90	4.88	1.00	1.00	5.75	2.25	5.63	7 lb. 7 oz.
3.250	1.375	3.75	1.00	3.90	4.88	1.00	1.00	5.75	2.50	5.88	8 lb. 9 oz.
4.000	1.000	4.50	0.75	4.70	4.88	1.00	1.00	6.50	2.25	5.63	10 lb. 5 oz.
4.000	1.375	4.50	1.00	4.70	4.88	1.00	1.00	6.50	2.50	5.88	11 lb. 7 oz.

<sup>1</sup>These are complete cylinders, not bolt-on kits.  
Dimensions in inches, for those not shown see MS4 basic cylinder drawing.

## MT1 Front Trunnion<sup>2</sup> Mounting Kit - TM-8 Series Only (Aluminum block with steel trunnion pins)

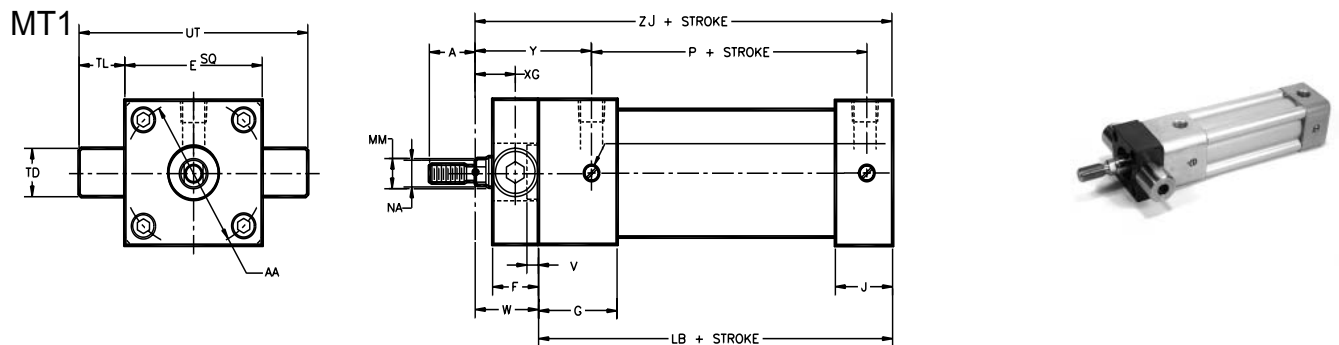

Model	MT1 [TM-8 Series]												
KIT PART NUMBER	BORE SIZE	MM ROD	E	F	W	AA	LB	TD	TL	UT	XG	ZJ	WEIGHT
R432013510	1.500	0.625	2.00	1.00	1.38	2.02	4.03	1.00	1.00	4.00	0.88	5.41	0 lb. 12 oz.
R432013507	2.000	0.625	2.50	1.00	1.38	2.60	4.03	1.00	1.00	4.50	0.88	5.41	1 lb. 0 oz.
R432013513	2.500	0.625	3.00	1.00	1.38	3.10	4.16	1.00	1.00	5.00	0.88	5.53	1 lb. 4 oz.
R432013489	3.250	1.000	3.75	1.00	1.50	3.90	4.88	1.00	1.00	5.75	1.00	6.38	1 lb. 12 oz.
R432013516	4.000	1.000	4.50	1.00	1.50	4.70	4.88	1.00	1.00	6.50	1.00	6.38	2 lb. 8 oz.

<sup>2</sup>These kits are for replacement only. For new cylinder, MT1 must be specified with cylinder due to rod extension being required.  
Dimensions in inches, for those not shown see MS4 basic cylinder drawing.

# Taskmaster® Pneumatic Cylinder

MT2 Mounts - 1.5" thru 4" bore



## MT2 Trunnion<sup>1</sup> Mount - TM-1 Series [NFPA compliant] Complete Cylinder Dimensions

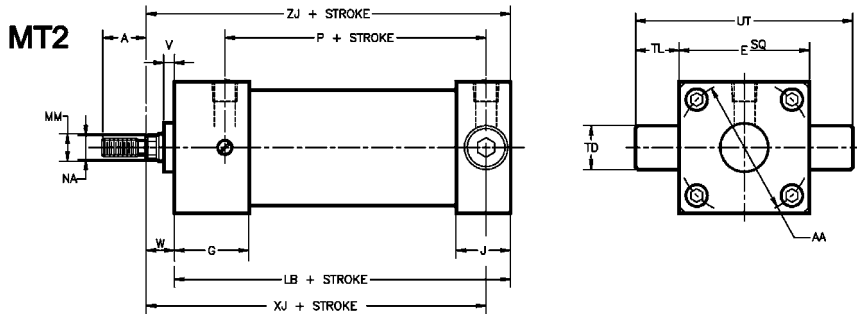

MT2 [TM-1 Series Complete Cylinder Dimensions]											
WEIGHT	BORE SIZE	MM ROD	E	W	AA	LB	TD	TL	UT	XJ	ZJ
2 lb. 2 oz.	1.500	0.625	2.00	0.63	2.02	4.03	1.00	1.00	4.00	4.12	4.66
2 lb. 12 oz.	1.500	1.000	2.00	1.00	2.02	4.03	1.00	1.00	4.00	4.50	5.04
2 lb. 15 oz.	2.000	0.625	2.50	0.63	2.60	4.03	1.00	1.00	4.50	4.12	4.66
3 lb. 9 oz.	2.000	1.000	2.50	1.00	2.60	4.03	1.00	1.00	4.50	4.50	5.04
3 lb. 0 oz.	2.500	0.625	3.00	0.63	3.10	4.16	1.00	1.00	5.00	4.25	4.78
3 lb. 10 oz.	2.500	1.000	3.00	1.00	3.10	4.16	1.00	1.00	5.00	4.61	5.16
7 lb. 7 oz.	3.250	1.000	3.75	0.75	3.90	4.88	1.00	1.00	5.75	5.00	5.63
8 lb. 9 oz.	3.250	1.375	3.75	1.00	3.90	4.88	1.00	1.00	5.75	5.25	5.88
10 lb. 5 oz.	4.000	1.000	4.50	0.75	4.70	4.88	1.00	1.00	6.50	5.00	5.63
11 lb. 7 oz.	4.000	1.375	4.50	1.00	4.70	4.88	1.00	1.00	6.50	5.25	5.88

Dimensions in inches, for those not shown see MS4 basic cylinder drawing.

<sup>1</sup>These are complete cylinders, not bolt-on kits.

## MT2 Trunnion Mounting Kit - TM-8 Series only (Aluminum block with steel trunnion pins)

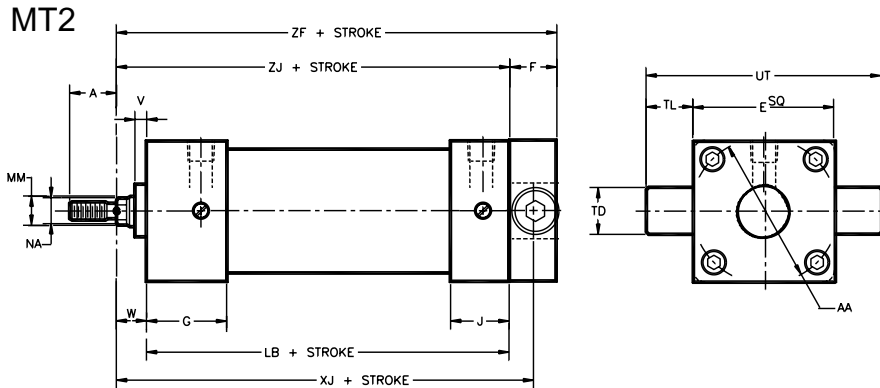

MT2 [TM-8 Series]															
Model	WEIGHT	KIT PART NUMBER	BORE SIZE	MM ROD	E	F	W	AA	LB	TD	TL	UT	XJ	ZF	ZJ
0 lb. 12 oz.		R432013510	1.500	0.625	2.00	1.00	0.59	2.02	4.03	1.00	1.00	4.00	5.13	5.63	4.63
1 lb. 0 oz.		R432013507	2.000	0.625	2.50	1.00	0.59	2.60	4.03	1.00	1.00	4.50	5.13	5.63	4.63
1 lb. 4 oz.		R432013513	2.500	0.625	3.00	1.00	0.59	3.10	4.16	1.00	1.00	5.00	5.25	5.75	4.75
1 lb. 12 oz.		R432013489	3.250	1.000	3.75	1.00	0.75	3.90	4.88	1.00	1.00	5.75	6.13	6.63	5.63
2 lb. 8 oz.		R432013516	4.000	1.000	4.50	1.00	0.75	4.70	4.88	1.00	1.00	6.50	6.13	6.63	5.63

Dimensions in inches, for those not shown see MS4 basic cylinder drawing.

# Taskmaster® Pneumatic Cylinder

MX1, 2, 3, 4 - Extended Tie Rod Mounting Kits



## MX1, 2, 3, 4 Kits (Extended Tie Rods) Mounting Kit

MX1, 2, 3, 4

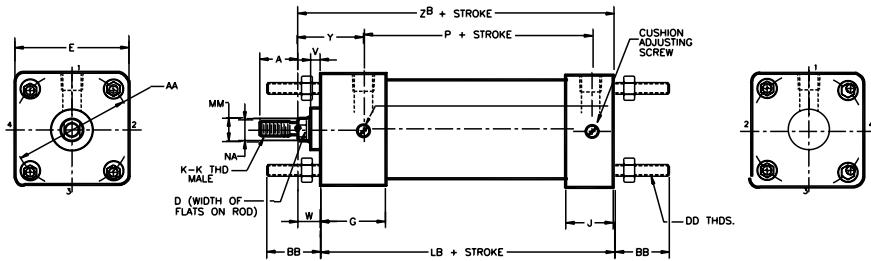

**NOTE:**

- MX1 - Tie rods extended both ends: Order (2) MX kits.
- MX2 - Tie rods extended cap end: Order (1) MX kit.
- MX3 - Tie rods extended head end: Order (1) MX kit.
- MX4 - Two tie rods extended both ends: Order (1) MX kit.

Model	MX1, 2, 3, 4													
KIT PART NUMBER	BORE SIZE	MM ROD	E	G	J	V	W*	AA	BB	DD	LB	RM	ZB*	WEIGHT
R432013684	1.500	0.625	2.00	1.72	1.13	0.25	0.59	2.02	1.31	1/4-28	4.03	1.13	4.62	0 lb. 2 oz.
R432013686	2.000	0.625	2.50	1.72	1.13	0.25	0.59	2.60	1.53	5/16-24	4.03	1.13	4.62	0 lb. 4 oz.
R432013686	2.500	0.625	3.00	1.72	1.25	0.25	0.59	3.10	1.53	5/16-24	4.16	1.13	4.75	0 lb. 4 oz.
R432013688	3.250	1.000	3.75	2.25	1.13	0.25	0.75	3.90	2.13	3/8-24	4.88	1.50	5.62	0 lb. 6 oz.
R432013688	4.000	1.000	4.50	2.25	1.13	0.25	0.75	4.70	2.13	3/8-24	4.88	1.50	5.62	0 lb. 6 oz.

Mounting kit only, order cylinder separately. These kits are not affected by rod size. Dimensions in inches, for those not shown see MS4 basic cylinder drawing.

\*Dimensions are for TM-8 series, for TM-1 series see MS4 basic cylinder drawing.

## D Double Rod

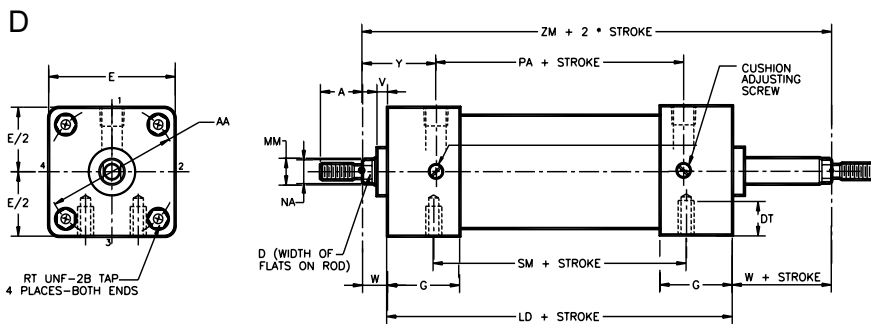

Model	D Double Rod															
BORE SIZE	MM ROD	E	G	V	W*	AA	DT	LD	NT	PA	RC	RT	SM	TN	XT	ZM*
1.500	0.625	2.00	1.72	0.25	0.59	2.02	0.38	4.63	1/4-20	2.31	0.47	1/4-28	1.94	0.63	1.94	5.81
2.000	0.625	2.50	1.72	0.25	0.59	2.60	0.50	4.63	5/16-18	2.31	0.50	5/16-24	1.94	0.88	1.94	5.81
2.500	0.625	3.00	1.72	0.25	0.59	3.10	0.69	4.63	3/8-16	2.31	0.50	5/16-24	1.94	1.25	1.94	5.81
3.250	1.000	3.75	2.25	0.25	0.75	3.90	0.75	6.00	1/2-13	2.81	0.53	3/8-24	2.62	1.50	2.44	7.50
4.000	1.000	4.50	2.25	0.25	0.75	4.70	0.75	6.00	1/2-13	2.81	0.53	3/8-24	2.62	2.06	2.44	7.50

Dimensions in inches, for those not shown see MS4 basic cylinder drawing.

\*Dimensions are for TM-8 series, for TM-1 series see MS4 basic cylinder drawing.

# Taskmaster® Pneumatic Cylinder

MR3 - 1.5" thru 4" bore Nose Mounting Kit



## MR3 Nose Mounting Kit (TM-8 Series Only)

MR3

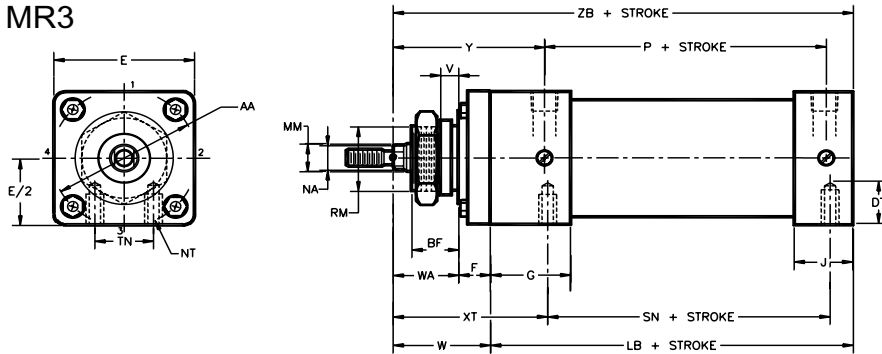

MR3 Nose Mount Kit\*

BORE SIZE	MM ROD	STANDARD CYLINDER PREFIX (TM-8 Series)	KIT PART NO.*	WEIGHT
1.50	0.625	TM-068204-	R432013497	0 lb. 9 oz.
2.00	0.625	TM-068207-	R432013499	0 lb. 12 oz.
2.50	0.625	TM-068210-	R432013501	0 lb. 13 oz.
3.25	1.000	TM-068213-	R432013503	1 lb. 4 oz.
4.00	1.000	TM-068216-	R432013505	4 lb. 4 oz.

These kits are for replacement only. For complete cylinders, order by description, using prefixes for cylinders shown.

\*TM-8 series only, not available for TM-1 series.

## Dimensions

E	F	V	W	Y	AA	BF	LB	RM	WA	XT	ZB	BK - THD
2.00	0.56	0.25	1.78	2.94	2.02	0.88	4.03	1.061	1.22	3.13	5.81	1.00 - 14
2.50	0.68	0.25	1.78	30.6	2.60	0.88	4.03	1.061	1.22	3.25	5.94	1.00 - 14
3.00	0.68	0.31	2.03	3.19	3.10	1.00	4.16	1.374	1.34	3.38	6.19	1.38 - 12
3.75	0.93	0.31	2.43	4.03	3.90	1.00	4.88	1.499	1.50	4.13	7.31	1.50 - 12
4.50	0.93	0.38	2.56	4.22	4.70	1.13	4.88	1.749	1.63	4.25	7.44	1.75 - 12

These dimensions are not affected by rod size. Dimensions in inches, for those not shown see MS4 basic cylinder drawing.



# Taskmaster® Pneumatic Cylinder

Accessories - 1.5" thru 4" bore



## Female Rod Clevis (Aluminum)

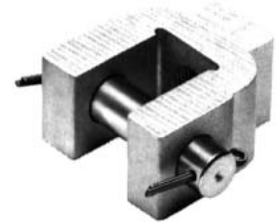
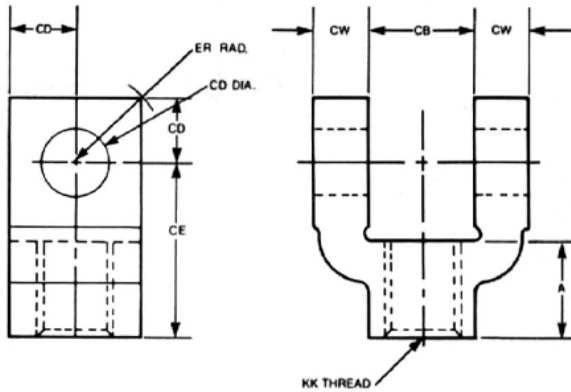

PART NO.	BORE	ROD	THREAD KK	A	CB	CD	CE	CW	ER	WEIGHT
R432012516	1.5, 2 & 2.5	0.625	1/2-20	0.75	0.75	0.50	1.50	0.50	0.72	0 lb. 9 oz.
R432013386	3.25 & 4	1.000	7/8-14	1.13	1.25	0.75	2.06	0.63	1.06	1 lb. 0 oz.

Includes pivot pin and retaining rings. For sizes not shown, see NFPA cylinder accessories.

## Eye Bracket (Aluminum)

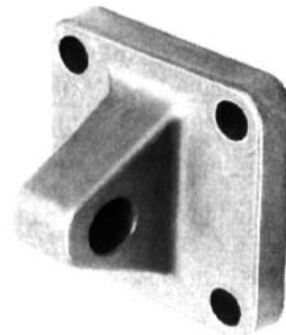
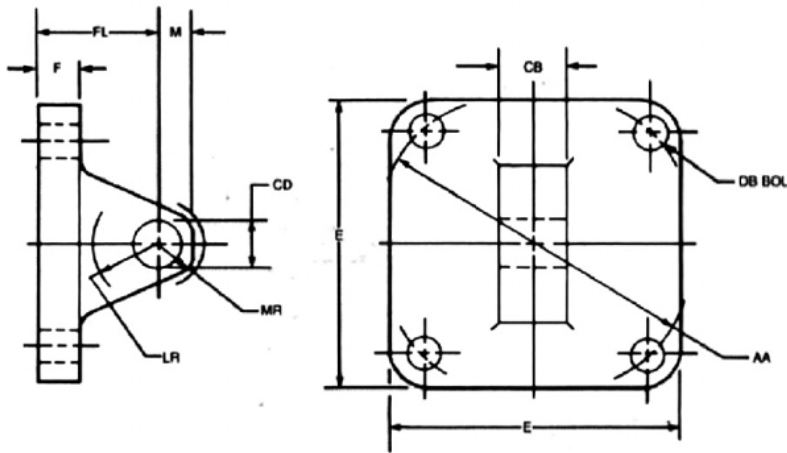

PART NO.	WEIGHT	BORE	E	F	M	AA	CB	CD	DB	FL	LR	MR
R432013368	0 lb. 4 oz.	1.50	2.00	0.38	0.50	2.02	0.75	0.50	0.25	1.13	0.63	0.53
R432012551	0 lb. 4 oz.	2.00	2.50	0.38	0.50	2.60	0.75	0.50	0.31	1.13	0.63	0.53
R432013376	0 lb. 8 oz.	2.50	3.00	0.38	0.50	3.10	0.75	0.50	0.31	1.13	0.63	0.53
R432008890	1 lb. 4 oz.	3.25	3.75	0.63	0.75	3.90	1.25	0.75	0.38	1.88	0.88	0.78
R432008892	1 lb. 8 oz.	4.00	4.50	0.63	0.75	4.70	1.25	0.75	0.38	1.88	0.88	0.78

Eye bracket mates with female rod clevis or MP1, MP2 mounts.

# Taskmaster® Pneumatic Cylinder

Accessories - 1.5" thru 4" bore



## Female Rod Eye (Steel)

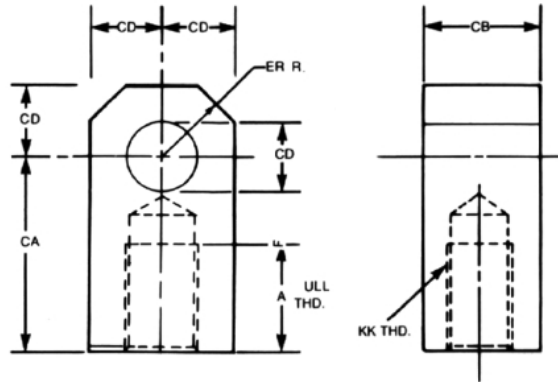

PART NO.	BORE	THREAD KK	A	CA	CB	CD	ER	WEIGHT
R432006533	1.5, 2 & 2.5	1/2-20	0.88	1.50	0.75	0.50	0.56	0 lb. 5 oz.
R432013437	3.25 & 4	7/8-14	1.13	2.06	1.25	0.75	0.84	1 lb. 0 oz.

For sizes not shown, see NFPA cylinder accessories.

## Clevis Bracket (Aluminum)

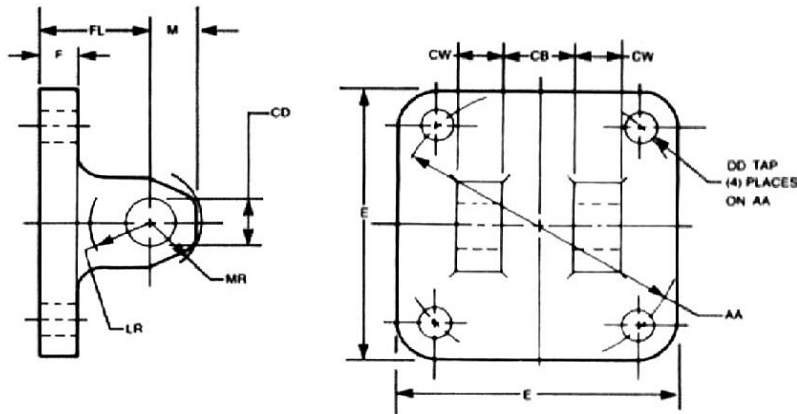

PART NO.	WEIGHT	BORE	E	F	M	AA	CB	CD	CW	DD	FL	LR	MR
R432013366	0 lb. 4 oz.	1.50	2.00	0.38	0.50	2.02	0.75	0.50	0.50	0.25	1.13	0.63	0.53
R432012511	0 lb. 4 oz.	2.00	2.50	0.38	0.50	2.60	0.75	0.50	0.50	0.31	1.13	0.63	0.53
R432013381	0 lb. 8 oz.	2.50	3.00	0.38	0.50	3.10	0.75	0.50	0.50	0.31	1.13	0.63	0.53
R432008891	1 lb. 2 oz.	3.25	3.75	0.63	0.75	3.90	1.25	0.75	0.63	0.38	1.88	0.88	0.78
R432008893	1 lb. 8 oz.	4.00	4.50	0.63	0.75	4.70	1.25	0.75	0.63	0.38	1.88	0.88	0.78

Clevis bracket mates with female rod eye or MP4 mount. For sizes not shown see NFPA cylinder accessories.

# Taskmaster® Pneumatic Cylinder

Accessories - 1.5" thru 4" bore



## ◆ Pivot Pin (Steel), includes retaining rings

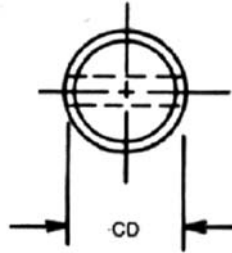
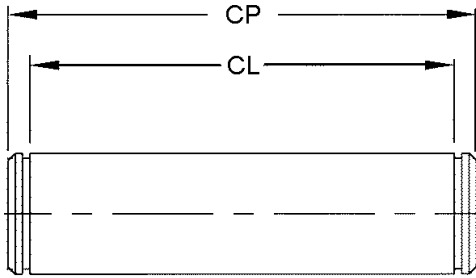

PART NO.	WEIGHT	BORE	CD	CL	CP
R433012619	0 lb. 4 oz.	1.5, 2 & 2.5	0.50	1.88	2.09
R433012621	0 lb. 8 oz.	3.25, 4, & 5	0.75	2.62	2.88
R433012623	0 lb. 13 oz.	6	1.00	3.12	3.38

For sizes not shown see NFPA cylinder accessories.

## ◆ Right Angle Flow Controls - 540 Series NPTF ports

Mounting directly on cylinder, thread sealant on male threads.  
360° swivel compact body.  
See SC-400 for additional details.

HOW TO ORDER:	Part Number	Description
	R432027182	Threaded inlet, 1/4" NPTF with screwdriver slot
	R432027183	Threaded inlet, 3/8" NPTF with screwdriver slot
	R432027184	Threaded inlet, 1/2" NPTF with screwdriver slot
	R432027186	Threaded inlet, 1/4" NPTF with knob adjustment
	R432027187	Threaded inlet, 3/8" NPTF with knob adjustment
	R432027188	Threaded inlet, 1/2" NPTF with knob adjustment
	R432027191	Push-in fitting, 1/4" NPTF x 1/4" tube, with slot
	R432027192	Push-in fitting, 3/8" NPTF x 3/8" tube, with slot
	R432027194	Push-in fitting, 1/4" NPTF x 1/4" tube, with knob
	R432027195	Push-in fitting, 3/8" NPTF x 3/8" tube, with knob



# Taskmaster® Pneumatic Cylinder

Optional Configurations



## ▲ Proximity Switches for 1 1/2" - 4" bore Taskmaster Cylinders

**Features** For all bore sizes of Taskmaster Cylinders  
 New, low-profile designs  
 Meets NEMA 1, 4, and 13  
 Easy to adjust  
 Handles from 6 VDC to 120 VAC (unless otherwise indicated)  
 LED indicators  
 Built-in surge suppression

**Switch specifications**  
 Single pole, normally open  
 0° F to 160° F



### ► Operation

AVENTICS magnetically operated Proximity Switches are the normally open, single pole, and single throw style. The switch is designed to close in the presence of a magnetic field, produced by the magnetic piston of the cylinder.  
 Signals, useful for operating lights, valves, or other devices, are possible anywhere along the stroke of the cylinder.  
 Multiple switches may be spaced as close as 0.62 inches by using more than one rib of the cylinder for mounting.

### Part No. (all include clamp)

Symbol	Type	Bore Size	Fig.	mA Rating	Part No.	Desc. & Cable Length L
	Reed	1.5" - 6"	2 & 5	500	<b>R432008720</b>	Surge suppression, LED, 3' leads
	Reed	1.5" - 6"	2 & 5	500	<b>R432008721</b>	Surge suppression, LED, 12' leads
	Reed	1.5" - 6"	2 & 3	500	<b>R432008722</b>	Surg. supp.,LED,Brad Harrison®,1' leads
	Reed	1.5" - 6"	2 & 4	500	<b>P -026966-00003</b>	Surge supp.,LED,Molex/GM, 4" leads
	Reed	1.5- 2.5"	1	25	<b>R432008731</b>	3-pin quick disconnect (8mm), 6" leads
	Reed	1.5- 2.5"	1 & 5	25	<b>R432008724</b>	Pigtail, two 3' leads
	Reed	1.5- 2.5"	1 & 5	25	<b>R432008725</b>	Pigtail, two 9' leads
	Reed	1.5- 2.5"	1 & 3	25	<b>R432008726</b>	Brad Harrison 1' leads
	Reed	1.5- 2.5"	1 & 4	25	<b>P -026966-00007</b>	Molex/GM
	NPN	1.5- 2.5"	1 & 5	300/6-24VDC	<b>R432008730</b>	9' pigtail
	NPN	1.5- 2.5"	1	300/6-24VDC	<b>R432008733</b>	3-pin quick disconnect (8mm), 6" leads
	PNP	1.5- 2.5"	1 & 5	300/6-24VDC	<b>R432008729</b>	9' pigtail
	PNP	1.5- 2.5"	1	300/6-24VDC	<b>R432008732</b>	3-pin quick disconnect (8mm), 6" leads

Note: See following page for 3-pin connector cables with female connector

Proximity Switch & Clamp - Figure 1

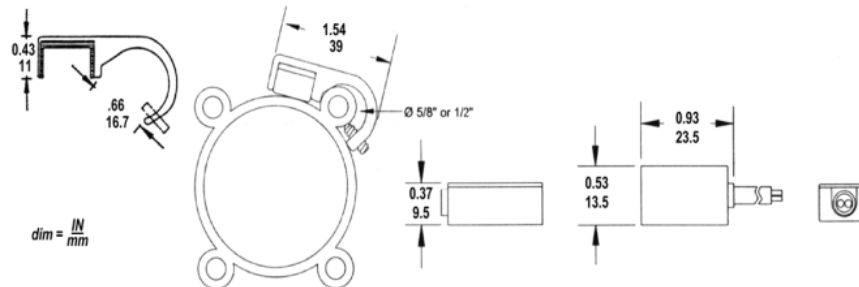

# Taskmaster® Pneumatic Cylinder

Optional Configurations



## Proximity Reed Switch & Clamp - Figure 2

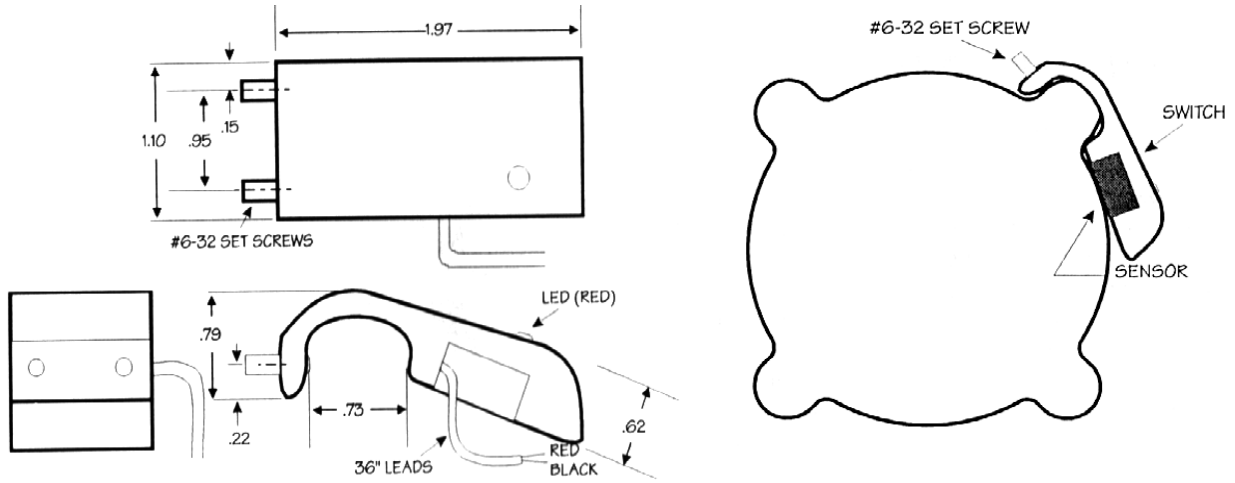

### Connector styles

Schematic	Figure No.	Description
<p><b>BRAD HARRISON CONNECTOR</b></p> <p>12MM MALE PLUG WITH EXTERNAL THREADS CATALOG #804008A09M020. ONE FOOT LONG CABLE.</p>	3	Brad Harrison® style
<p><b>MOLEX MICRO-C: 12MM INVERTED MALE PLUG</b> GM WINDSOR STANDARD APPROVED MICRO CORDS. <b>MOLEX/GM CONNECTOR</b></p> <p>PIN #2 (+) PIN #4 (-)</p>	4	Molex/GM style
<p><b>CABLE SPECIFICATIONS:</b> 22 AWG, 300V, 80', 2 LEADS.</p> <p><b>PIGTAIL</b></p> <p>BROWN (POS.) WHITE (NEG.)</p>	5	Pigtail

# Taskmaster® Pneumatic Cylinder

## Optional Configurations



### Integral Position Sensor

The TASKMASTER Cylinder with Integral Position Sensor includes an internal position sensor (potentiometer) for infinite rod position indication.

#### Application

Used where knowledge of cylinder position is needed through entire stroke, at a point remote from the cylinder. A voltmeter graduated in inches or percent may be used as a position read-out device.

### Integral Position Sensor

#### Sensor Features

- Integrated into cylinder, hence protected from external damage
- Conductive plastic construction
- Resistance approximately 1500 ohms per inch
- Linearity 1 percent of stroke
- Temperature range 0 to 160°F (-40°F optional)
- Maximum power rating 0.1 watts per inch
- Electrical connection: DIN connector (same as Series 740 Valve)
- Can be checked with simple voltmeters
- Does not require non-rotating rod
- Position sensing is absolute (not incremental); position indication is not lost after power failure.

#### Cylinder Specifications

- 1.5" thru 4" bore Taskmaster cylinders
- All standard mounts applicable
- Cushioning available
- Strokes: 4, 6, 8, 10, 12 inches.
- Additional strokes available in 2" increments, 18" maximum.



#### Part Number and Stroke (KK2 Male rod thread)

Bore	4" stroke	6" stroke	8" stroke	10" stroke	12" stroke
1.50	TM-069860-03040	R432020385	TM-069860-03080	TM-069860-03100	TM-069860-03120
2.00	TM-069862-03040	R434002679	R434004036	TM-069862-03100	R434002690
2.50	TM-069866-03040	TM-069866-03060	TM-069866-03080	TM-069866-03100	TM-069866-03120
3.25	TM-069868-03040	TM-069868-03060	TM-069868-03080	TM-069868-03100	TM-069868-03120
4.00	R434002676	TM-069870-03060	TM-069870-03080	TM-069870-03100	R434002675

Other rod end thread options are available on request.

### Electro-Pneumatic Positioner Specifications

- Stroke: Any length in 1" increments, to 10"  
2" increments between 10" and 16" strokes
- Accuracy: +/- .050" or 1 percent full stroke, whichever is greater
- Repeatability: +/- .050"
- Stroking Speed: Approx.: Fast 2"/sec., slow .5"/sec.
- Operating Temp.: 41°F to 122°F
- Power Requirements: 24vdc, 600 ma
- Signal Options: 0-10vdc, 0-20ma, 5k ohm pot.
- Feedback Device: Linear potentiometer, internally mounted
- Supply Pressure: 100 psi nominal, 125 psi max. at 3 micron filtration recommended
- Optional Meter Drive: 0-20 ma

#### Application

Wherever infinite positioning requirements allow electrical analog control signals. Interfaces with computer, PLC or simple potentiometer. Consists of cylinder with integral sensor, optimized valving, and an electronic controller. Available in bore sizes 1-1/2 thru 4" and strokes up to 16"; single or dual stroking speed control available.

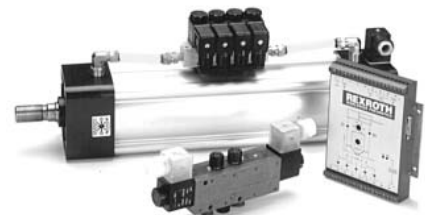

### Load Capacities per Bore Size

Bore size (inches)	1.5	2	2.5	3.25	4
Load rating (lbs)	35	63	98	166	250

At 100 psi supply pressure, 1 percent positioning accuracy.

# Taskmaster® Pneumatic Cylinder

## Optional Configurations



FIGURE 1.

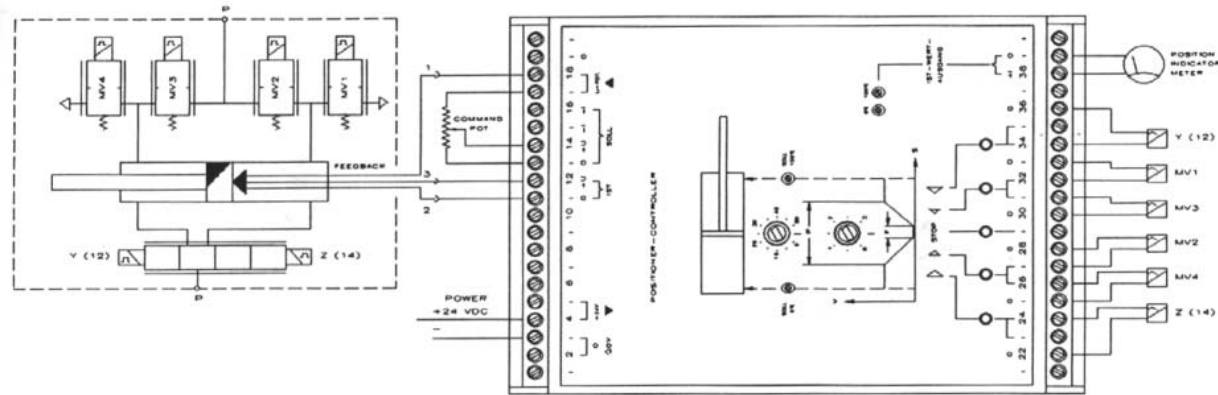

The basic concept involves a cylinder with integral feedback potentiometer in conjunction with a controller and matched solenoid valves. Figure 1 represents the system layout. The figure represents a 2 speed system utilizing (4) 2-way solenoid valves (energized in pairs) for slow speed and a double solenoid, 4-way, closed center for fast speed.

The two speed positioners offers the fastest response without sacrificing accuracy.

The single speed positioners are applied in areas that require accuracy and only slow speed, or fast speeds that do not require 1% accuracy.

For single speed applications, only one set of valves is necessary.

For the slow retract, (mv1) and (mv3) solenoid valves are energized simultaneously.

Valves (mv2) and (mv4) are energized for the slow extend command.

The double solenoid valve is energized for either the fast retract or for fast extend.

The controller constantly monitors the command signal and compares the feedback signal the position sensor located in the cylinder.

If the command signal is greater than the feedback, the controller will energize the solenoid valves associated with extension.

The retract solenoid valves are energized when the command signal is less than the feedback signal.

If the command equals the feedback signal, all of the solenoid valves are De-energized and position is maintained.

The two speed controller consists of a narrow window and a wide window comparator.

A large difference between the command and feedback results in energization of both sets of solenoid valves.

When the position approaches the set-point command, only the slow speed valves are energized.

A unique feature is that each set of solenoids is pulsed before complete shut-off to provide a stepped, gradual deceleration of the load.

The width of sensitivity and the width of deceleration is adjustable on the controller to allow tailoring of the positioner for each application.

### E-P Positioner Selection

#### HOW TO SELECT:

1. Determine the amount of force required for the application.
2. Determine the available supply pressure.
3. Note length of stroke required.
4. Check and note accuracy and speed requirements.
5. Determine if meter drive output is desired.
6. Contact sales representative or factory for component selection.

# Taskmaster® Pneumatic Cylinder

## Optional Configurations



### Taskmaster® Cylinder/Series 740™ Valve Combination Specifications

1-1/2", 2", 2-1/2", 3-1/4", & 4" Bore  
 100" stroke maximum, 1/4" minimum stroke  
 Male or female rod thread  
 Pressure: 20 to 150 PSI (2 position valves)  
 50 to 150 PSI (3 position valves)  
 Temperature: 5°F to 140°F  
 Standard Voltages: 6-24 VDC  
 110-220 VAC  
 Non-lube cylinder  
 Positive air cushions at both ends (optional)  
 Most NFPA mounts

#### ► Features

Air pilot or solenoid operated, single or double  
 2 position spring returned valve or 3 position closed center valve  
 Indicator light optionally available  
 Valve has built in flow controls and integrated fittings  
 Manual override  
 Valve mounts at head or cap  
 Valve has polyacetal body  
 Corrosion resistant package, pre-lubricated  
 Reduced air consumption  
 Simplified customer plumbing  
 Easy valve interchange (no screws to remove)  
 Reduce labor cost



Valves are not factory assembled to cylinders. Valve mounting bracket and piping are factory assembled.  
 Additional Series 740 valve features and specifications may be found in the valve catalog pages.  
 Select Series 740 valve from the following pages.

### ► Taskmaster Cylinders with Mounting Bracket and Piping - For TM-8 Series Only\*

Base Model Number	Bore	Rod Size	KK2 Male Thread
TM-027924-....	1-1/2	5/8	1/2-20
TM-026049-....	2	5/8	1/2-20
TM-026050-....	2-1/2	5/8	1/2-20
TM-026433-....	3-1/4	1	7/8-14
TM-026481-....	4	1	7/8-14

\*TM-1 compliant cylinders are available; see order code.  
 These TM-8 compliant cylinders include valve mounting bracket complete with tubing.  
 Above cylinders are modified to accept mounting bracket.  
 Standard Taskmaster cylinders may be modified by ordering field mounting kit,  
 Part Number R432008535 (does not contain piping from head to cap).  
 Estimated operating speeds in inches per second at 100 PSI are: 1-1/2" bore,  
 50; 2", 28; 2-1/2", 18; 3-1/4", 9; and 4", 7.

### ◆ How to Order Series 740™ Combinations

Select the appropriate part number from the list and add the 4-digit suffix which describes cushioning and stroke. Order mounting kits separately.  
**4-DIGIT SUFFIX EXPLANATION**  
 The first digit indicates the degree of cushioning..  
 0-Noncushioned  
 1-Cushioned in head end only  
 2-Cushioned in cap end only  
 3-Cushioned in both ends  
 Second and third digits are used to indicate the stroke in inches.  
 Fourth digit is used to indicate additional eighths of an inch of stroke.  
**EXAMPLE:** Both ends cushioned, 10-1/2 stroke, 1-1/2 bore, KK2 THD model code would be TM-027924-03104



# Taskmaster® Pneumatic Cylinder

## Optional Configurations



### Series 740 Valve Options

Type		Diaphragm poppet valve
Pressure range	Minimum	20 psi
	Maximum	150 psi
Flow		$C_v = 0.7$ to $0.95$
Temperature range	Solenoid	5°F to 122°F
	Air Pilot	5°F to 140°F
Medium		Compressed air, lubricated or non-lubricated
Port sizes	3/8"; 5/16" and 8 mm also available [not shown]	
Materials	Body / Seals	Polyacetal plastic w/ Buna N seals
Operating voltages		DC $\pm 10\%$
	50 Hz	AC - 20% + 10%
	60 Hz	AC - 10% + 20%
Power consumption	DC 24 V	2,14 W
Inrush power	AC 220/230 V 50/60 Hz 6,60 / 5,50 VA	
Holding power	AC 220/230 V 50/60 Hz 4,18 / 3,30 VA	
Protection with el. connector		NEMA 4 [IP 65 to DIN VDE 0470]
Duty cycle	ED	100%
Switching times	$t_{on}$	18 ms
	$t_{off}$	32 ms
[24VDC at 85 psi]		



### Note

Electrical connectors must be ordered separately; one per solenoid required.  
For entire line of Series 740 Valve options and accessories, see SC-300 catalog.

Series 740 Valve - Air Pilot		
Part Number	Description	
R432013808	Single Air Pilot, spring return	
R432013810	Double Air Pilot, 2 position	
Series 740 Valve - 2 Position, Solenoid Operated		
Single Solenoid, Air Spring Return	Description	Double Solenoid
5727495270	110V-50Hz/120V-60Hz	R432016659
R432016655	220V-50Hz/240V-60Hz	R432016660
R432016656	6 VDC	R432016661
R432016657	12 VDC	R432016662
5727490220	24 VDC	R432016663
R432016658	24 VAC-50/60Hz	R432016664
Series 740 Valve - 3 Position, Double Solenoid Operated		
Closed Center	Description	Exhaust Open Center
R432016670	110V-50Hz/120V-60Hz	R432016665
R432016671	220V-50Hz/240V-60Hz	R432016666
R432016672	6 VDC	--
R432016673	12 VDC	R432016667
R432016674	24 VDC	R432016668
R432016675	24 VAC-50/60Hz	R432016669

Caution: Simultaneous activation of both solenoids will provide full supply pressure to both delivery and exhaust ports. Care should be taken to avoid applications where a back pressure spike can occur from heavy inertia loads.

Solenoid Connectors - Order One per Solenoid		
Strain Relief Connectors	Description	1/2" Conduit Connectors*
8941000302	Non-lighted	--
R432013747	Non-lighted for Wireways	--
--	Metallic Non-lighted	R432015781
--	Non-lighted Molded Plastic	R432015626
R432013726	120VAC Lighted	R432008421
R432013728	240VAC Lighted	R432008422
R432013729	12VDC Lighted	R432008423
R432013730	24VDC Lighted	R432008424
R432015629	24VAC Lighted	R432008425

\*CSA approved

# Taskmaster® Pneumatic Cylinder

Technical Data and Design Features, 5" and 6" bores



## Technical Data, 5"-6" bore sizes

Pressure Rating	200 psi maximum
Temperature Range	0° to 160°F ambient, 200°F intermittent
Medium	Compressed air, non-lubricated or lubricated
Strokes	Furnished to nearest 1/8"
Pneumatic Cushioning	Optional on both ends
Mountings	One integral, plus ten NFPA mountings
Ports	NPTF dryseal tapered
Materials	Hard anodized aluminum
Tube	303 Stainless Steel
Tie Rods	Die cast aluminum
Head and Cap	Steel, hard chrome plated, oversize available
Piston Rod	

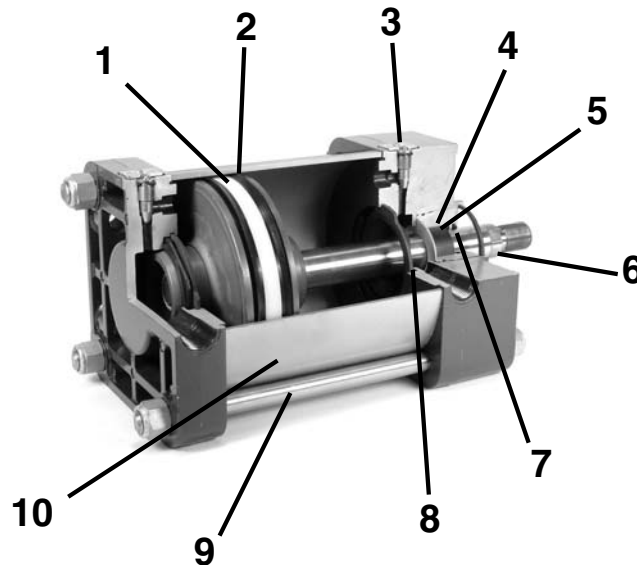

## TaskMaster Design Features, 5" - 6"

### Design Features

1. Non-metallic wear strip provides extended service even under harsh side loads.
2. Pressure energized Teflon coated cup-type piston seals provide positive, low friction sealing. They are self-regulating and wear compensating for extended service life.
3. Highly accurate external cushion adjustment.
4. Durable rod bearing. Dependable non-scoring, corrosion-resistant graphite material. Cartridge can be removed without cylinder disassembly.
5. Positive rod seal. Pressure energized polyurethane cup seal is wear compensating for longer life.
6. High strength steel piston rod. Hard chrome plated for maximum durability with a 100,000 psi minimum yield. Oversize rod available. Case hardened to 50-55 Rockwell "C", finished to 15 microinches or better.
7. Protective rod wiper. Polyurethane lip-type wiper increases cylinder life by preventing damaging dirt from entering the cylinder gland.
8. Self-aligning cushions. Teflon-coated, floating check valve allows greater cylinder speed.
9. 303 stainless steel tie rods for maximum corrosion resistance.
10. Rugged, non-corrosive tubing. Reinforced, hard anodized aluminum.

► Magnetic piston (for use with sensors) available as an option. Select appropriate sensor from proximity switch section.

# Taskmaster® Pneumatic Cylinder

How To Order Cylinders - 5" and 6" bore



## Basic Ordering Code 5" - 6" Cylinders

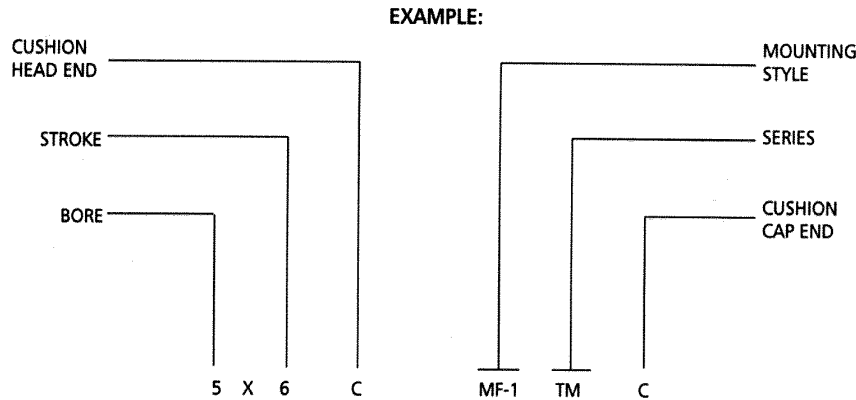

### Part Number Listing:

A current part number with description listing is available at [www.aventics.com/us/TaskmasterCyl](http://www.aventics.com/us/TaskmasterCyl)

### Notes:

- The basic ordering code must accompany the part number when ordering. Notes:
- If magnetic piston (for use with sensors) is desired, it must also be specified when ordering. Select sensor from proximity switch section.
- Normal stroke tolerance +/- 1/16".
- Cushioning not recommended for under 3" stroke.

### Old Part Numbers Reference for 5" and 6" bores

5" BORE PART NUMBER	5" BORE ROD DIA.	5" BORE ROD THREAD	5" & 6" MOUNT	6" BORE PART NUMBER	6" BORE ROD DIA.	6" BORE ROD THREAD
P -067997-00000	1.00	3/4-16	MF-1	P -068003-00000	1.38	1-14
P -068000-00000	1.38	1-14	MF-1	P -068006-00000	1.75	1 1/4-12
P -068009-00000	1.00	3/4-16	MF-2	P -068015-00000	1.38	1-14
P -068012-00000	1.38	1-14	MF-2	P -068018-00000	1.75	1 1/4-12
P -068021-00000	1.00	3/4-16	MF-5	P -068027-00000	1.38	1-14
P -068024-00000	1.38	1-14	MF-5	P -068030-00000	1.75	1 1/4-12
P -068033-00000	1.00	3/4-16	MF-6	P -068039-00000	1.38	1-14
P -068036-00000	1.38	1-14	MF-6	P -068042-00000	1.75	1 1/4-12
P -068045-00000	1.00	3/4-16	MP-2	P -068051-00000	1.38	1-14
P -068048-00000	1.38	1-14	MP-2	P -068054-00000	1.75	1 1/4-12
P -068057-00000	1.00	3/4-16	MS-1	P -068063-00000	1.38	1-14
P -068060-00000	1.38	1-14	MS-1	P -068066-00000	1.75	1 1/4-12
P -067985-00000	1.00	3/4-16	MS-4	P -067991-00000	1.38	1-14
P -067988-00000	1.38	1-14	MS-4	P -067994-00000	1.75	1 1/4-12

MP1 mount available, contact factory.

### 5 DIGIT SUFFIX EXPLANATION

The first digit will always be a zero. The second digit indicates the degree of cushioning:

- 0 - Non-cushioned
- 1 - Cushioned in head end only
- 2 - Cushioned in cap end only
- 3 - Cushioned in both ends

Third and fourth digits are used to indicate the stroke in inches.

Fifth digit is used to indicate additional eighths of an inch of stroke.

EXAMPLE: Both ends cushioned, 10-1/2" stroke, 1-1/2" bore, KK2 THD = P -068174-03104

# Taskmaster® Pneumatic Cylinder

MS4 - 5" and 6" bore  
Basic Cylinder



## MS4 [Basic Cylinder]

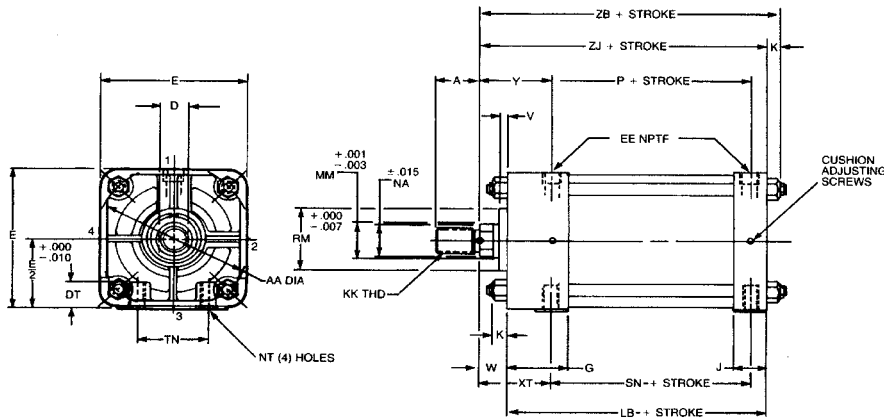

EE = 5" bore 1/2-14 NPTF, 6" bore 3/4-14 NPTF

MS4 Mount																				
Bore Size	MM Rod	E	G	J	K	P	V	W	Y	AA	DT	NA	LB	NT TAP	RM	SN	TN	XT	ZB	ZJ
5.00	1.00	5.50	2.31	1.19	0.61	2.88	0.25	0.75	2.44	5.80	1.06	0.94	5.13	5/8-11	2.374	2.88	2.69	2.44	6.49	5.88
5.00	1.38	5.50	2.31	1.19	0.61	2.88	0.25	1.00	2.69	5.80	1.06	1.31	5.13	5/8-11	2.374	2.88	2.69	2.69	6.74	6.13
6.00	1.38	6.50	2.69	1.44	0.61	3.13	0.25	0.88	2.81	6.90	1.19	1.31	5.75	3/4-10	2.624	3.13	3.25	2.81	7.23	6.63
6.00	1.75	6.50	2.69	1.44	0.61	3.13	0.25	1.13	3.06	6.90	1.19	1.69	5.75	3/4-10	2.624	3.13	3.25	3.06	7.49	6.88

5" and 6" bore Taskmaster pre-lubricated cylinders are versatile, durable, yet economical.

The basic cylinder is furnished with MS4, side tapped mount with ten additional NFPA mountings available.

Corrosion resistant aluminum head, cap and tube plus stainless steel tie rods make the Taskmaster Cylinder excellent where corrosion is a problem.

These cylinders can be applied with medium-heavy loadings where large masses are to be moved or where frequency is high.

The optional pneumatic cushioning is adjustable and gives quick acceleration.

Each bore size offers the advantage of an oversize rod that can be used for larger loads and longer strokes.

Dimension in inches.

# Taskmaster® Pneumatic Cylinder

Rod Thread Options



Rod Size/ Thread Options

## TASKMASTER ROD THREAD OPTIONS

Male Rod

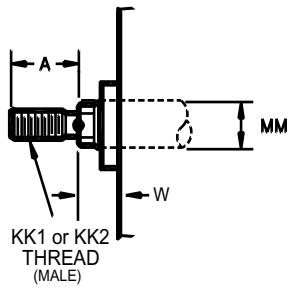

Female Rod

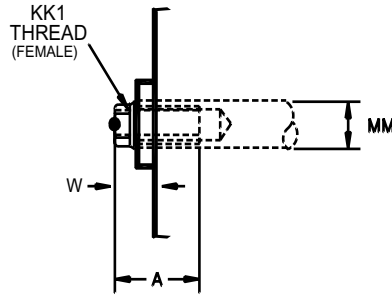

Studded Rod

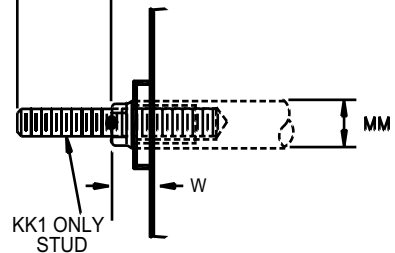

		Rod Thread Options				
BORE SIZE	MM ROD	KK1 THD	KK2 THD	A	D*	W
5.000	1.000	3/4-16	7/8-14	1.13	0.88	0.75
5.000	1.375	1-14	1 1/4-12	1.63	1.13	1.00
6.000	1.375	1-14	1 1/4-12	1.63	1.13	0.88
6.000	1.750	1 1/4-12	1 1/2-12	2.00	1.50	1.13

**NOTE**

Male thread available in KK1 and KK2 thread sizes. KK1 male furnished when thread not specified. Female thread available in KK1 thread only. KK1 studded male rod end available on request.

\*D = width across rod flats

# Taskmaster® Pneumatic Cylinder

MF1 - 5" and 6" bore  
MF2



## MF1 Head Rectangular Flange

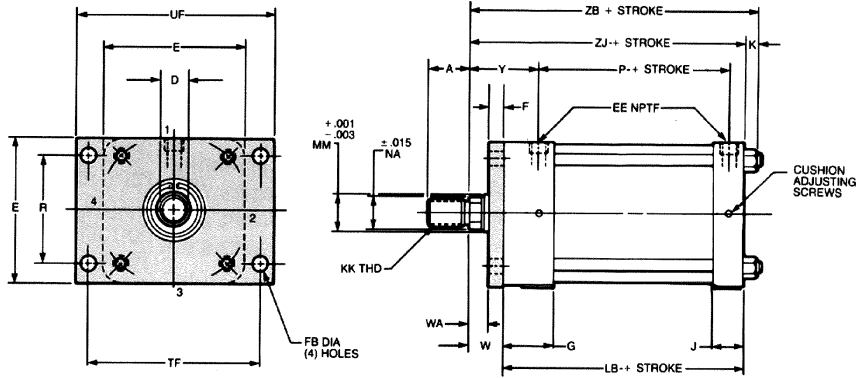

Model	MF1 Head Rectangular Flange												
BORE SIZE	MM ROD	E	F	K	R	W	FB	LB	TF	UF	WA	ZB	ZJ
5.000	1.000	5.50	0.63	0.61	4.10	0.75	0.53	5.13	6.63	7.63	0.13	6.49	5.88
5.000	1.375	5.50	0.63	0.61	4.10	1.00	0.53	5.13	6.63	7.63	0.38	6.74	6.13
6.000	1.375	6.50	0.75	0.61	4.88	0.88	0.53	5.75	7.62	8.62	0.12	7.23	6.63
6.000	1.750	6.50	0.75	0.61	4.88	1.12	0.53	5.75	7.62	8.62	0.38	7.49	6.88

Dimensions in inches, for those not shown see MS4 basic cylinder drawing.

## MF2 Cap Rectangular Flange

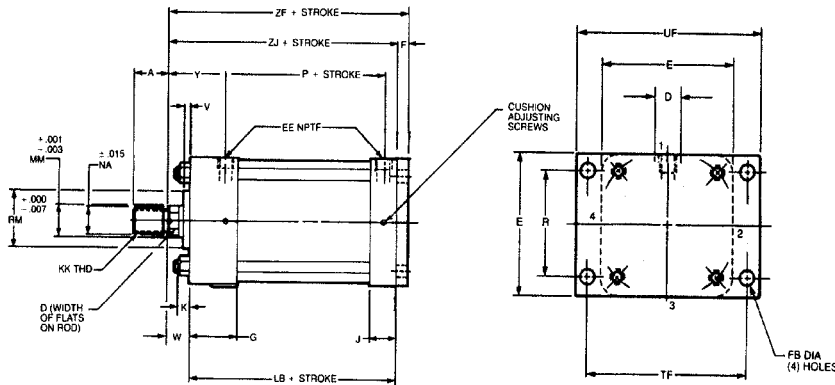

Model	MF2 Cap Rectangular Flange												
BORE SIZE	MM ROD	E	F	K	R	W	FB	LB	TF	UF	ZF	ZJ	
5.000	1.000	5.50	0.63	0.61	4.10	0.75	0.53	5.13	6.63	7.63	6.50	5.88	
5.000	1.375	5.50	0.63	0.61	4.10	1.00	0.53	5.13	6.63	7.63	6.75	6.13	
6.000	1.375	6.50	0.75	0.61	4.88	0.88	0.53	5.75	7.63	8.63	7.38	6.63	
6.000	1.750	6.50	0.75	0.61	4.88	1.13	0.53	5.75	7.63	8.63	7.63	6.88	

Dimensions in inches, for those not shown see MS4 basic cylinder drawing.

# Taskmaster® Pneumatic Cylinder

MF5 - 5" and 6" bore  
MF6



## MF5 Head Square Flange

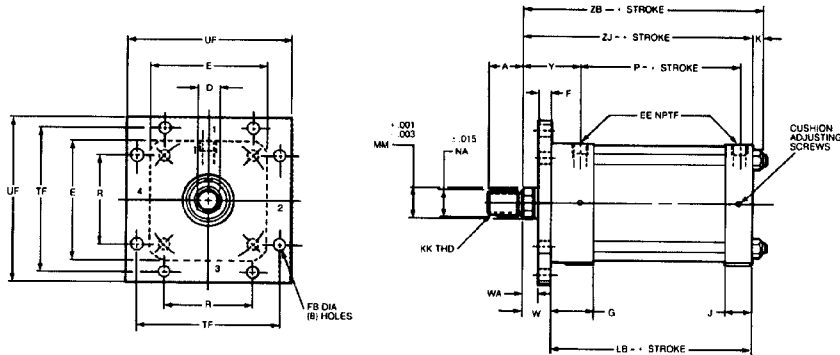

Model	MF5 Head Square Flange												
BORE SIZE	MM ROD	E	F	K	R	W	FB	LB	TF	UF	WA	ZB	ZJ
5.000	1.000	5.50	0.63	0.61	4.10	0.75	0.53	5.13	6.63	7.63	0.13	6.49	5.88
5.000	1.375	5.50	0.63	0.61	4.10	1.00	0.53	5.13	6.63	7.63	0.38	6.73	6.13
6.000	1.375	6.50	0.75	0.61	4.88	0.88	0.53	5.75	7.63	8.63	0.12	7.23	6.63
6.000	1.750	6.50	0.75	0.61	4.88	1.13	0.53	5.75	7.63	8.63	0.37	7.49	6.88

Dimensions in inches, for those not shown see MS4 basic cylinder drawing.

## MF6 Cap Square Flange (Steel)

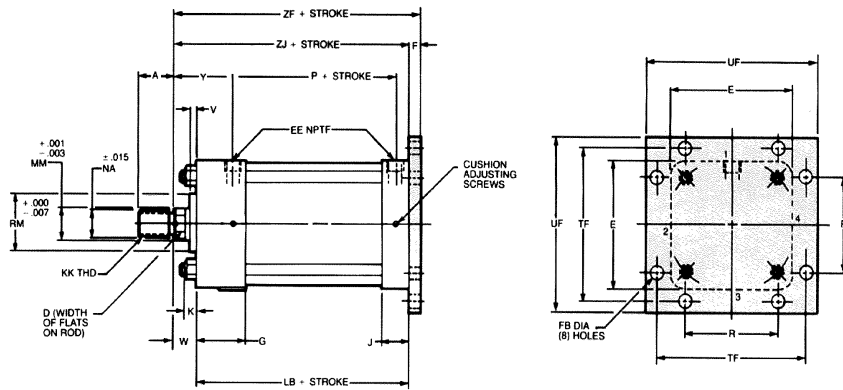

Model	MF6 Cap Square Flange												
BORE SIZE	MM ROD	E	F	K	R	W	FB	LB	TF	UF	ZF	ZJ	
5.000	1.000	5.50	0.63	0.61	4.10	0.75	0.53	5.13	6.63	7.63	6.50	5.88	
5.000	1.375	5.50	0.63	0.61	4.10	1.00	0.53	5.13	6.63	7.63	6.75	6.13	
6.000	1.375	6.50	0.75	0.61	4.88	0.88	0.53	5.75	7.63	8.63	7.38	6.63	
6.000	1.750	6.50	0.75	0.61	4.88	1.12	0.53	5.75	7.63	8.63	7.63	6.88	

Dimensions in inches, for those not shown see MS4 basic cylinder drawing.

# Taskmaster® Pneumatic Cylinder

MP2 - 5" and 6" bore  
MS1



## MP2 Detachable Clevis (Aluminum)

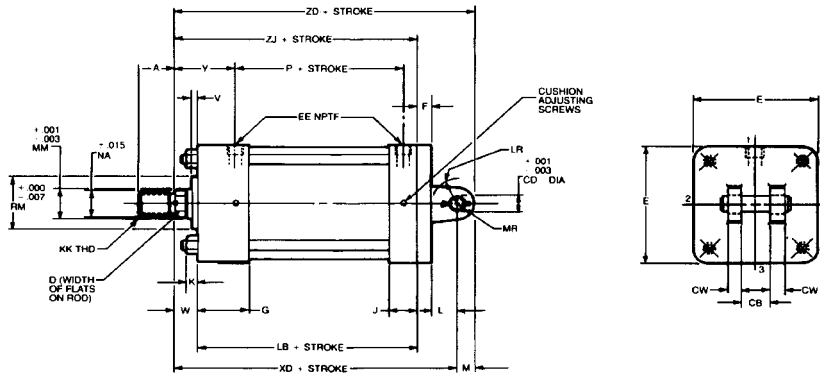

Model	MP2 Detachable Clevis														
BORE SIZE	MM ROD	E	F	K	L	M	CB	CD	CW	LB	LR	MR	XD	ZD	ZJ
5.000	1.000	5.50	0.63	0.61	1.25	0.75	1.25	0.750	0.63	5.13	0.88	0.75	7.75	8.50	5.88
5.000	1.375	5.50	0.63	0.61	1.25	0.75	1.25	0.750	0.63	5.13	0.88	0.75	8.00	8.75	6.13
6.000	1.375	6.50	0.75	0.61	1.50	1.00	1.50	1.000	0.75	5.75	1.19	1.00	8.88	9.88	6.63
6.000	1.750	6.50	0.75	0.61	1.50	1.00	1.50	1.000	0.75	5.75	1.19	1.00	9.13	10.13	6.88

Dimensions in inches, for those not shown see MS4 basic cylinder drawing.

## MS1 Side End Angles (Steel)

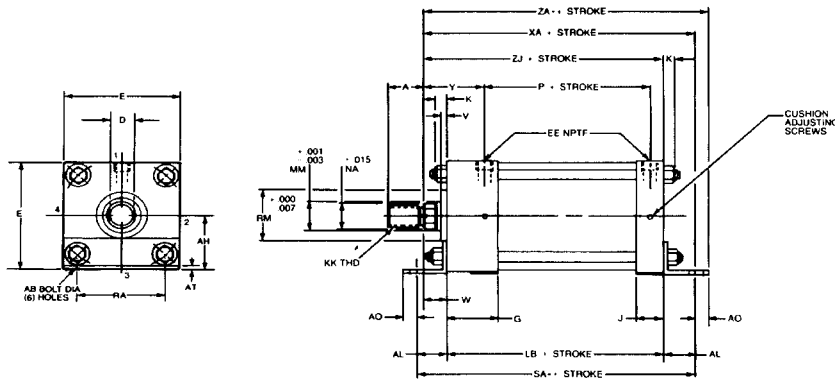

Model	MS1 Side End Angles														
BORE SIZE	MM ROD	E	K	AB	AH	AL	AO	AT	LB	RA	SA	XA	ZA	ZJ	
5.000	1.000	5.50	0.61	0.69	2.75	1.38	0.63	0.19	5.13	4.25	7.88	7.25	7.88	5.88	
5.000	1.375	5.50	0.61	0.69	2.75	1.38	0.63	0.19	5.13	4.25	7.88	7.50	8.13	6.13	
6.000	1.375	6.50	0.61	0.81	3.25	1.38	0.63	0.19	5.75	5.25	8.50	8.25	8.63	6.63	
6.000	1.750	6.50	0.61	0.81	3.25	1.38	0.63	0.19	5.75	5.25	8.50	8.25	8.88	6.88	

Dimensions in inches, for those not shown see MS4 basic cylinder drawing.



# Taskmaster® Pneumatic Cylinder

MX1, MX2, MX3, MX4 - 5" and 6" bore  
D Double Rod



## MX1, MX2, MX3, MX4 Tie Rods Extended

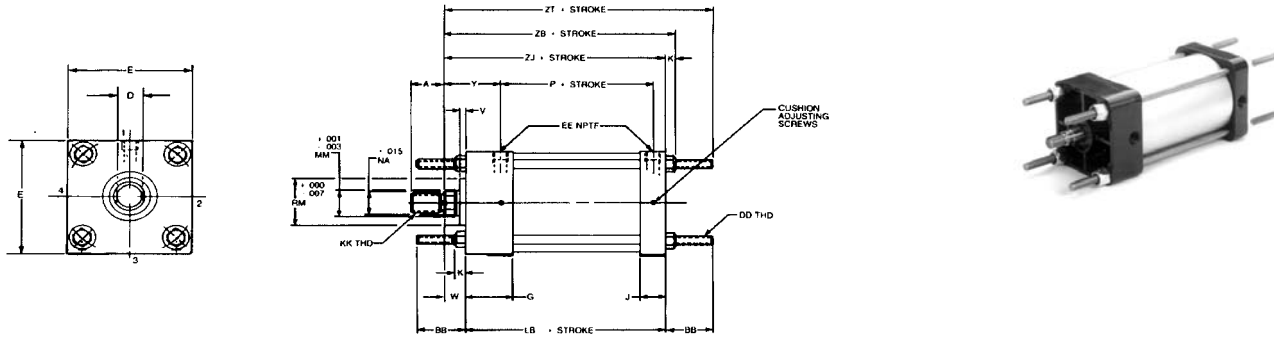

MX1 - Tie rods extended both ends  
MX2 - Tie rods extended cap end

MX3 - Tie rods extended head end  
MX4 - Two tie rods extended both ends

Model	MX1, MX2, MX3, MX4										
BORE SIZE	MM ROD	E	K	W	AA	BB	DD	LB	ZB	ZJ	ZT
5.000	1.000	5.50	0.61	0.75	5.80	1.81	1/2-20	5.13	6.49	5.88	7.69
5.000	1.375	5.50	0.61	1.00	5.80	1.81	1/2-20	5.13	6.74	6.13	7.94
6.000	1.375	6.50	0.61	0.88	6.90	1.81	1/2-20	5.75	7.23	6.63	8.84
6.000	1.750	6.50	0.61	1.12	6.90	1.81	1/2-20	5.75	7.49	6.88	8.69

Dimensions in inches, for those not shown see MS4 basic cylinder drawing.

## D Double Rod

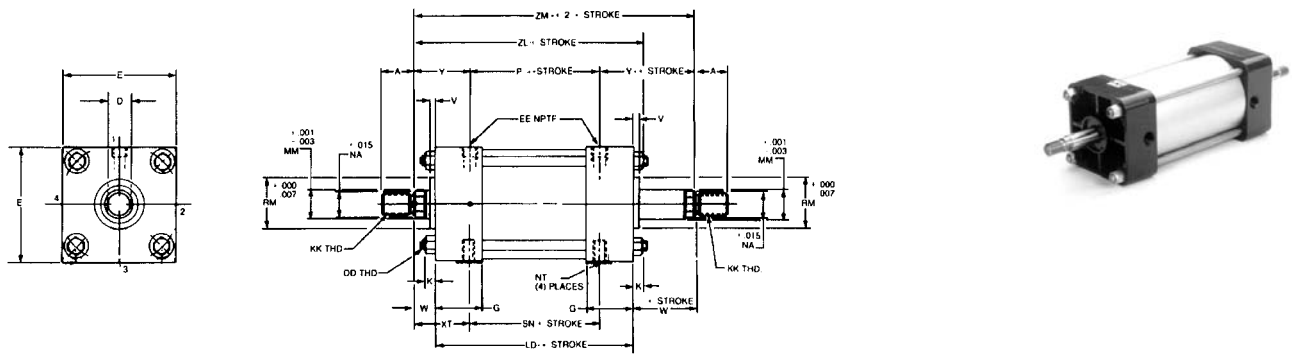

Technical Data																				
BORE SIZE	MM ROD	E	G	K	P	V	W	Y	AA	DD	DT	EE	LD	NT	RM	SN	TN	XT	ZL	ZM
5.000	1.000	5.50	2.31	0.61	2.88	0.25	0.75	2.44	5.80	1/2-20	1.06	1/2-14	6.25	5/8-11	2.374	2.88	2.69	2.44	7.61	7.75
5.000	1.375	5.50	2.31	0.61	2.88	0.25	1.00	2.69	5.80	1/2-20	1.06	1/2-14	6.25	5/8-11	2.374	2.88	2.69	2.69	7.86	8.25
6.000	1.375	6.50	2.69	0.61	3.13	0.25	0.88	2.81	6.90	1/2-20	1.19	3/4-14	7.00	3/4-10	2.624	3.13	3.25	2.81	8.49	8.75
6.000	1.750	6.50	2.69	0.61	3.13	0.25	1.13	3.06	6.90	1/2-20	1.19	3/4-14	7.00	3/4-10	2.624	3.13	3.25	3.06	8.74	9.25

Dimensions in inches, for those not shown see MS4 basic cylinder drawing.

# Taskmaster® Pneumatic Cylinder

Accessories - 5" and 6" bore



## Female Rod Clevis (Steel)

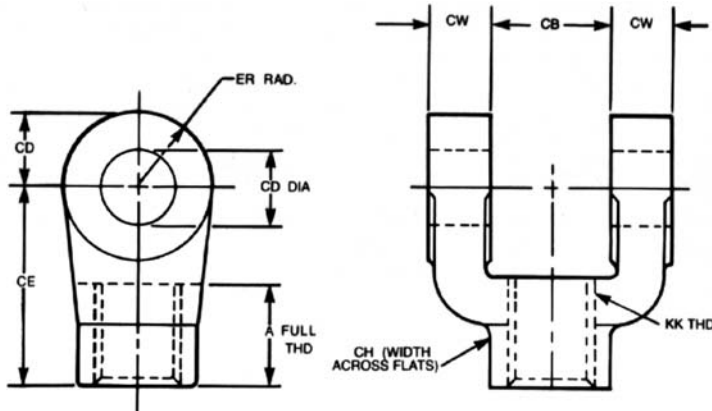

PART NO.	BORE SIZE	ROD SIZE	A	CB	CD	CE	CH	CW	ER	KK	WGT.
R433012603	5"	1.000	1.13	1.25	0.750	2.38	1.25	0.63	0.75	3/4-16	1 lb. 4 oz.
R432012515*	5"	1.000	1.13	1.25	0.750	2.06	--	0.63	1.06	7/8-14	0 lb. 7 oz.
R433012604	5" & 6"	1.375	1.63	1.50	1.000	3.13	1.63	0.75	1.00	1-14	2 lb. 8 oz.
R433012606	6"	1.750	2.00	2.00	1.375	4.13	2.00	1.00	1.38	1-1/4-12	6 lb. 6 oz.
R433012607	6"	1.750	2.25	2.50	1.750	4.50	2.38	1.25	1.75	1-1/2-12	11 lb. 8 oz.

\* Aluminum. Dimensions in inches.

## Eye Bracket (Steel)

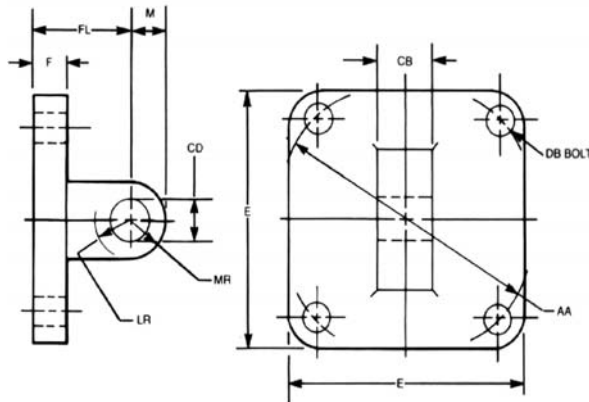

PART NO.	WEIGHT	BORE SIZE	E	F	M	AA	CB	CD	DB	FL	LR	MR
R433012640	3 lb. 4 oz.	5"	3.50	0.63	0.75	3.60	1.25	0.750	0.50	1.88	1.00	0.75
R433012641	6 lb. 4 oz.	5" & 6"	4.50	0.75	1.00	4.60	1.50	1.000	0.63	2.25	1.38	1.00
R433012642	10 lb. 4 oz.	6"	5.00	0.88	1.38	5.40	2.00	1.375	0.63	3.00	2.00	1.38
R433012643	16 lb. 12 oz.	6"	6.50	0.88	1.75	7.00	2.50	1.750	0.88	3.13	2.25	1.75

Dimensions in inches. This part mates with female rod clevis, or MP1, MP2 mounts.

# Taskmaster® Pneumatic Cylinder

Accessories - 5" and 6" bore



## Female Rod Eye (Steel)

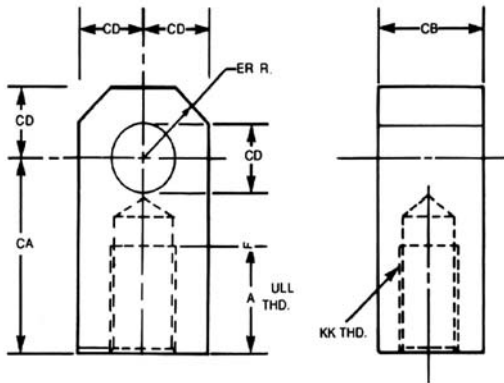

PART NO.	BORE SIZE	ROD SIZE	A	CA	CB	CD	ER	KK	WEIGHT
R433012611	5"	1.000	1.13	2.06	1.25	0.750	0.81	3/4-16	1 lb. 4 oz.
R433012612	5"	1.000	1.13	2.38	1.50	1.000	1.13	7/8-14	2 lb. 3 oz.
R433012613	5" & 6"	1.375	1.63	2.81	1.50	1.000	1.13	1-14	2 lb. 8 oz.
R433012614	5" & 6"	1.375	2.00	3.44	2.00	1.375	1.69	1-1/4-12	6 lb. 6 oz.
R433012614	6"	1.750	2.00	3.44	2.00	1.375	1.69	1-1/4-12	6 lb. 6 oz.
R433012615	6"	1.750	2.25	4.00	2.50	1.750	2.06	1-1/2-12	11 lb. 8 oz.

Dimensions in inches.

## Clevis Bracket (Steel)

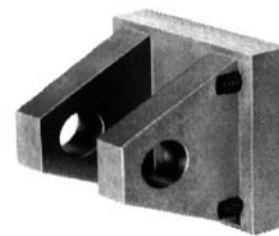
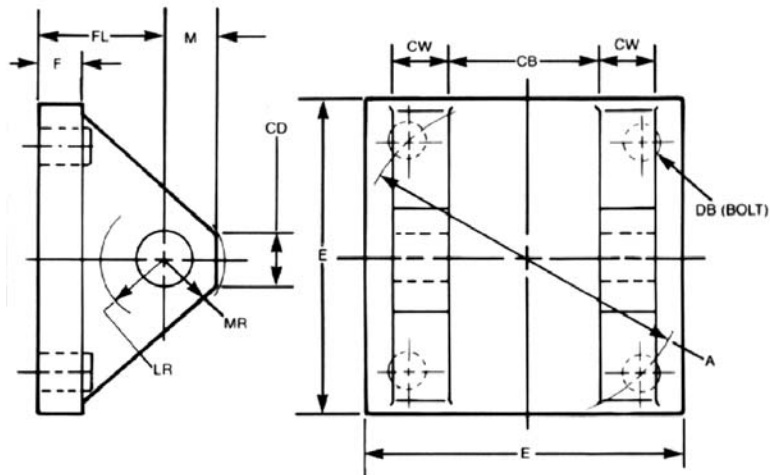

PART NO.	WEIGHT	BORE SIZE	E	F	M	AA	CB	CD	CW	DB	FL	LR	MR
R433012633	3 lb. 4 oz.	5"	3.50	0.63	0.75	3.60	1.25	0.750	0.63	1/2-20	1.88	0.88	1.25
R433012634	6 lb. 2 oz.	5" & 6"	4.50	0.75	1.00	4.60	1.50	1.000	0.75	5/8-18	2.25	1.19	1.13
R433012635	11 lb. 8 oz.	6"	5.00	0.88	1.38	5.40	2.00	1.375	1.00	5/8-18	3.00	1.75	1.63
R433012636	20 lb. 0 oz.	6"	6.50	0.88	1.75	7.00	2.50	1.750	1.25	7/8-14	3.13	2.13	2.13

Dimensions in inches. This part mates with female rod eye or MP4 mount.

# Taskmaster® Pneumatic Cylinder

Accessories - 5" and 6" bore



## Pivot Pin (Steel), including retaining rings

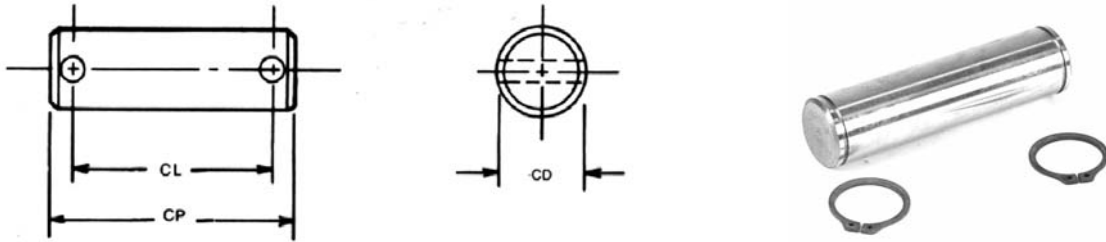

PART NO.	BORE SIZE	CD	CL	CP	WEIGHT
R433012621	5"	0.750	2.50	3.00	0 lb. 8 oz.
R433012623	5" & 6"	1.000	3.00	3.63	0 lb. 13 oz.
R433012625	6"	1.375	4.00	4.63	2 lb. 0 oz.
R433012627	6"	1.750	5.00	5.63	3 lb. 14 oz.

Dimensions in inches.

## MP1 Bracket - Cast Iron (for mating with clevis bracket)

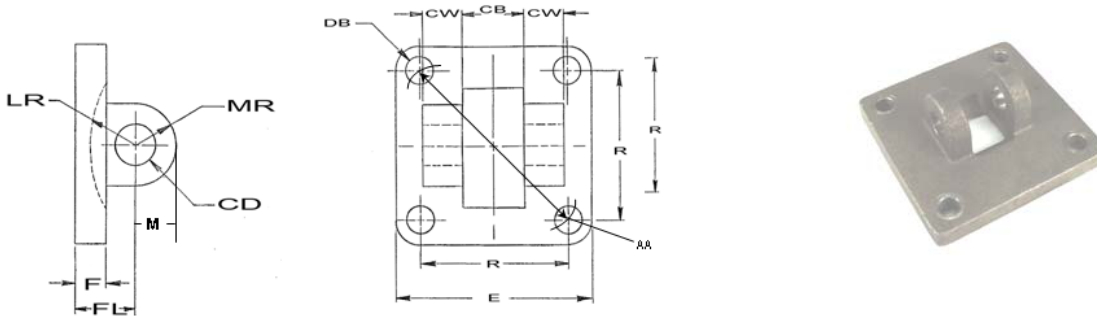

Part Number	Bore	E	F	R	AA	CW	CB	CD	DB	FL	LR	MR	M
R432015746	5"	5.50	0.62	4.10	5.80	0.63	1.26	0.75	0.53	1.25	0.88	0.88	0.75
R432015747	6"	6.50	0.75	4.88	6.90	0.75	1.51	1.00	0.53	1.50	1.13	1.25	1.00

Dimensions in inches.

# Taskmaster® Pneumatic Cylinder

Installation and Service Information



## INSTALLATION AND SERVICE INFORMATION

TABLE OF CONTENTS	PAGE NO.
Description, Warning	36
Installation	36
Standard & Special Repair Kits (1-1/2" – 6" Bore)	37
Operation	38
Standard Specifications	38
Adjustments	38
General Maintenance & Repair Recommendations	38
Parts List & Assembly Drawing (1-1/2" – 4" Bore)*	39
Parts List & Assembly Drawing (1-1/2"—4" Bore)**	40
Major Repair, Maintenance, and Testing (1-1/2" – 4" Bore)	41
Basic Cylinder Parts List & Assembly Drawing (5" & 6" Bore)	42
Major Repair, Maintenance & Testing (5" & 6" Bore)	43
Double Rod Cylinder Assembly Drawings (All Bores)	44

## GENERAL INFORMATION

### DESCRIPTION

Taskmaster Pre-Lubricated Pneumatic cylinders are available in 1-1/2" - 6" bores. The basic cylinder is furnished with an MS4 side tapped mount, with up to 12 additional NFPA mountings available. The popular mounting kits can be assembled to the basic cylinder on the 1-1/2" - 4" bore. Most mounting kits should be ordered separately from the cylinder. Basic cylinder part numbers, mounting kit and accessory part numbers for 1-1/2" - 4" bore cylinders are listed on the catalog pages. The available mounting kits for 1-1/2" - 4" bore are MS4 (basic), MF1, MF2, MP1, MP2, MP4, MS1, MS2, MT1, MX1, 2, 3, & 4. The current generation of 1-1/2" - 4" bore cylinders begin with "TM" model codes. Model codes beginning "TM-8" are replacement for the original "P" number cylinders. Model codes beginning with "TM-1" match NFPA standards for rod and port dimensions.

The 5" and 6" bore cylinders are ordered with the desired mount. Part numbers for cylinders and accessories are listed on the catalog pages. The available mounts are: MS4, MF1, MF2, MF5, MF6, MP2, MS1, MX1, 2, 3, & 4. Double rod models are available in all bore sizes.

Double rod models are available in all bore sizes.

### WARNINGS – INSTALLATION AND MOUNTING

The user of these devices must conform to all applicable electrical, mechanical, piping and other codes in the installation, operation or repair of these devices.

**INSTALLATION!** Do not attempt to install, operate or repair these devices without proper training in the technique of working on pneumatic systems and devices, unless under trained supervision. Compressed air systems contain high levels of stored energy. Do not attempt to connect, disconnect or repair these products when a system is under pressure. Always exhaust the pressure from an air system before performing any service work. Failure to do so can result in serious personal injury. Disconnect the electrical power supply before connecting or servicing a solenoid operated valve.

**MOUNTING!** Devices should be mounted and positioned in such a manner that they cannot be accidentally operated.

### INSTALLATION

Outline dimensions for installation of basic cylinders, mounting kits, and cylinder accessories are shown on the catalog pages. Port sizes are shown on standard specification chart on page 38. Before mounting the cylinder, all air lines in the system should be blown clean to remove any harmful dirt or moisture. To prevent corrosion and an accumulation of foreign matter in the cylinder, a 10 MICRON or better AVENTICS filter should be installed in the supply line to the cylinder control valve.

Teflon-coated piston and rod seals plus factory pre-lubrication, eliminates the need for air line lubrications. (However, lubricators can be used if desired). A complete selection of air line lubricators are available from AVENTICS.

A very important consideration in mounting the Taskmaster cylinder is keeping the cylinder thrust as close as possible to the centerline of the piston rod and free of misalignment or side loading. Off-center thrust or side loads decrease the normal life of the rod bearing and seals, and can cause binding in the cylinder or linkage. Forcing rod, clevis pins, or mounting bolts into position indicates that the cylinder is not properly aligned, and permanent damage may result from such installation

\*For model codes beginning with "TM" and date code of L10-00 or later.

\*\*For part numbers beginning with "P"

Note: For "TM" part numbers with date code prior to L10-00 contact factory.

# Taskmaster® Pneumatic Cylinder

Installation and Service Information



## Repair Kits and Parts

### ROD CARTRIDGE KIT (see Note 1)

Bore	Rod Size	Part Number	
1-1/2, 2 & 2 1/2"	5/8	R432015242 R432013557	(Std.) (Viton)
3-1/4 & 4	1	R432015245 R432015482	(Std.) (Viton)
5	1 1-3/8	R432014626 R432014630	(Std*) (Std*)
6	1-3/8 1-3/4	R432014637 R432014641	(Std*) (Std*)

### PISTON & TUBE SEAL KITS

#### Standard Cylinders (repairs all versions)

Bore	Part No. (std.) Tube seals	Part No. Viton Tube seals
1-1/2"	R432015250	R432008802
2"	R432015256	R432008753
2-1/2"	R432015263	R432008550
3-1/4"	R432015269	R432015270
4"	R432015279	R432015280
5"	R432014614	
6"	R432014620	

### ROD CARTRIDGE KIT (see Note 2)

Description	Part Number
1 1/2" bore, 5/8" rod, cushion @2	R434001403
1 1/2" bore, 5/8" rod, non-cushioned	R434001375
2" bore, 5/8" rod, cushion @2	R434001396
2" bore, 5/8" rod, non-cushioned	R434001394
2 1/2" bore, 5/8" rod, cushion @2	R434001366
2 1/2" bore, 5/8" rod, non-cushioned	R434004054
3 1/4" bore, 1" rod, cushion @2	R434001367
3 1/4" bore, 1" rod, non-cushioned	R434001368
4" bore, 1" rod, cushion @2	R434001370
4" bore, 1" rod	R434001371

### PISTON & TUBE SEAL KITS

#### Magnetic (original version only)

Includes tube seals, piston seals and piston wear strip.

Bore	Part Number
1-1/2"	R432015637
2"	R432015643
2-1/2"	R432015648
3-1/4"	R432015654
4"	R432015659

### CUSHION KIT (see Note 1)

Description	Part Number
1-1/2"	R432009056
2, 2-1/2"	R432015238
3-1/4", 4"	R432015240
5"	R432014608
6"	R432014610

### MAGNETIC PISTON KIT \*

Bore	Part Number
1-1/2	R432015636
2	R432015642
2-1/2	R432015647
3-1/4	R432015653
4	R432009771

\*Replacement only, for orig. design TaskMaster. Includes Magnetic piston, followers, seals and magnets.

### CYLINDER LUBE GREASE

Description	Part Number
5 oz. tube	R431001590

(The cylinder is pre-lubricated at the factory. However, when replacing seals, lubricate all rubber parts with cylinder lube grease.)

### PISTON KITS

(see Note 3)

Bore	Part Number
1-1/2	R432009715
2	R432009728
2-1/2	R432009744
3-1/4	R432009760
4	R432009771

Note 1: For Part number starting with "P". Also "TM" or "R" date code later than L10-00 or 00W41.

Note 2: For part no. starting with "TM" with date code of L09-00 or before, standard seals, with ports @1.

Note 3: For part numbers starting with "TM" or "R" with date code later than L10-00 or 00W41.

# Taskmaster® Pneumatic Cylinder

Installation and Service Information



## 1 1/2" – 6" Bore General Information

### OPERATION

Air pressure supplied to the cap-end port moves the piston rod to its extended position. Pressure supplied to the head end port moves the piston rod to its retracted position. See the catalog for forces developed by each cylinder.

### STANDARD SPECIFICATIONS

#### BORE SIZES

NFPA standard, 1-1/2", 2", 2-1/2", 3-1/4", 4", 5", & 6"

#### PRESSURE RATING

200 PSI air

#### TEMPERATURE RANGE

0°F to 160°F ambient

#### STROKES

Standard strokes furnished to nearest 1/8". Normal stroke tolerance +/- 1/16". Closer stroke tolerances available; consult factory.

#### MOUNTINGS

Basic mountings plus 12 additional NFPA mountings.

#### CUSHIONING

Optional on both ends for all bore sizes.

#### PRE-LUBRICATED DESIGN

Teflon-coated piston and rod seals plus factory pre-lubrication eliminates the need for air line lubrication.

#### ROD END THREADS

KK2 male thread is standard for 1-1/2"-- 4" bores for "TM-8" and "P" part numbers.

KK1 male thread is standard for 1-1/2" – 4" bores for "TM-1" part numbers.

KK1 male thread is standard for 5" and 6" bore.

KK1 female, KK1 (studded) male and either KK1 or KK2 male are optional on all bore sizes.

#### PISTON ROD

Chrome-plated, high carbon steel polished to 15 microfinish.  
Stainless steel (316/303) available for maximum corrosion resistance. Oversize rods are available on "TM-1" models of 1-1/2" – 4" bores and on 5" and 6" bores.

#### TUBE

Hard anodized extruded aluminum for lightweight, high strength and maximum corrosion resistance used in 1-1/2" - 4". Seamless aluminum tubing used in 5" and 6" bore.

#### PORTS

NPTF dryseal tapered threads. Available only in sizes shown.

BORE	NPTF*	NPTF**
1-1/2", 2", 2-1/2"	1/4-18	3/8-18
3-1/2", 4"	3/8-18	1/2-14
5"	1/2-14	
6"	3/4-14	

\*For "TM-8" or "P" part numbers.

\*\*For "TM-1" part numbers.

### CYLINDER WEIGHTS\*

BORE SIZE	ROD SIZE	CYLINDER WEIGHT ZERO STROKE (POUNDS)	ADDITIONAL WEIGHT PER INCH OF STROKE (POUNDS)
1-1/2"	5/8	1.65	0.205
2"	5/8	2.50	0.250
2-1/2"	5/8	3.54	0.280
3-1/4"	1	7.00	0.450
4"	1	9.87	0.548
5"	1	10.70	0.640
5"	1-3/8	11.50	0.840
6"	1-3/8	15.60	0.880
6"	1-3/4	16.90	1.140

\*Weights based on standard (first) rod sizes.

### ADJUSTMENT

An adjustable needle valve is furnished as an integral part of the head and cap on all cushioned cylinders. This needle valve controls the rate at which trapped air is allowed to vent from the head or cap. Turn the needle valve clockwise to increase the amount of cushioning and counterclock-wise to decrease the amount of cushioning.

### GENERAL MAINTENANCE & REPAIR RECOMMENDATIONS

Maintenance periods should be scheduled in accordance with frequency of use and working environment of the cylinder. All cylinders must be visually inspected for wear and given an "in system" operating performance and leakage test at least once a year. If these visual observations indicate cylinder repair is required, the cylinder must be removed, repaired and tested.

A major overhaul is recommended at one million cycles. However, where frequency of use is such that it would require more than two years to obtain one million cycles, the cylinder must be overhauled at the two year period.

When it is determined that the cylinder requires a major repair as a result of the one million cycles, one year routine inspection, or the two year service period has elapsed, the device must be disassembled, cleaned, inspected, parts replaced as required, rebuilt and tested for leakage, and proper operation prior to installation. Refer to MAJOR REPAIR, MAINTENANCE INSTRUCTION, and TEST PROCEDURES.



# Taskmaster® Pneumatic Cylinder

Installation and Service Information



## 1-1/2" - 4" Bore Size Basic Cylinder Parts List

(For model numbers beginning with R, or "TM" and date code of L10-00 or later.)

### Basic MS4 Parts List - Single Rod Model\*

Ref.	Qty.	Description	Part Number by Bore Size				
			1-1/2"	2"	2-1/2"	3-1/4"	4"
1	4	Screw, Head	R432015529	R432015531	R432015531	R432015533	R432015533
2	1	Head, TM-8 Cylinder	R432009478	R432009493	R432009504	R432009513	R432009520
		Head, TM-1 Cyl., Standard Rod	R432009793	R432009805	R432009818	R432009826	R432009833
		Head, TM-1 Cyl., Oversize Rod	R432009841	R432009843	R43209846	R432009852	R432009857
		Rod Cartridge Kit, Standard Rod	R432015242	R432015242	R432015242	R432015245	R432015245
		Rod Cartridge Kit, Oversize Rod	R434001391	R434001391	R434001391	R432014630	R432014630
3	1	Retaining Ring, Rod Bearing	Repair kit	Repair kit	Repair kit	Repair kit	Repair kit
4	1	Rod Bearing	includes	includes	includes	includes	includes
5	1	Rod Wiper	ref. numbers	ref. numbers	ref. numbers	ref. numbers	ref. numbers
6	1	Rod Seal	3, 4, 5 & 6	3, 4, 5 & 6	3, 4, 5 & 6	3, 4, 5 & 6	3, 4, 5 & 6
7	2	Cushion Kit	R432009056	R432015238	R432015238	R432015240	R432015240
		Piston & Tube Seal Kit	R432015250	R432015256	R432015263	R432015269	R432015279
8	2	Tube Seal O'ring	Repair kit	Repair kit	Repair kit	Repair kit	Repair kit
9	1	Piston Rod Seal	includes	includes	includes	includes	includes
10	2	Piston Seal	ref. numbers	ref. numbers	ref. numbers	ref. numbers	ref. numbers
11	1	Piston Wear Ring	8, 9,10 & 11	8, 9,10 & 11	8, 9,10 & 11	8, 9,10 & 11	8, 9,10 & 11
		Piston Kit, Standard Rod	R432009715	R432009728	R432009744	R432009760	R432009771
		Piston Kit, Oversize Rod	R432009716	R432009729	R432009745	R432009762	R432009773
12	1	Piston	Rep. kit incl.	Rep. kit incl.	Rep. kit incl.	Rep. kit incl.	Rep. kit incl.
13	2	Follower, Piston	ref. numbers	ref. numbers	ref. numbers	ref. numbers	ref. numbers
14	1	Retaining Nut, Piston & Rod	8 thru 14	8 thru 14	8 thru 14	8 thru 14	8 thru 14
15	1	Piston Rod, Male					
		Std. Rod, KK1 or KK2 Thread	various	various	various	various	various
		Oversize Rod, KK1 Thread	various	various	various	various	various
15a	1	Piston Rod, Female					
		Std. Rod, KK1 Thread	various	various	various	various	various
		Oversize Rod, KK1 Thread	various	various	various	various	various
16	1	Male Stud (use with ref. 15a)					
		7/16"-20 UNF-2A Thread	various	various	various	-	-
		1"-14 UNF-2A Thread	various	various	various	various	various
		3/4"-16 UNF-2A Thread	-	-	-	various	various
17	1	Tube, Body	various	various	various	various	various
18	1	Cap, TM-8 (w/needle vlv. assbly)	R432009486	R432009499	R432009508	R432009517	R432009525
		Cap, TM-1 (w/needle vlv. assbly)	R432009800	R432009811	R432009821	R432009829	R432009837
19	4	Screw, Cap	R432015528	R432015530	R432015530	R432015532	R432015532

\*Order repair parts for double rod cylinders by description and complete cylinder number. See page 44 for assembly drawing.

\*Single Rod Model

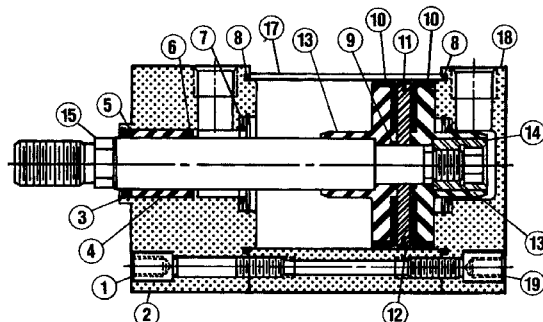
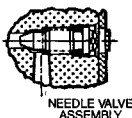



# Taskmaster® Pneumatic Cylinder

Installation and Service Information



## 1-1/2" - 4" Bore Size Basic Cylinder Parts List (For part numbers beginning with "P")

### Basic MS4 Parts List - Single Rod Model\*

Ref.	Qty.	Description	Part Number by Bore Size				
			1-1/2"	2"	2-1/2"	3-1/4"	4"
1	4	Screw, Head	R432015529	R432015531	R432015531	R432015533	R432015533
2	1	Head (w/needle valve assembly)	R432030813	R432030814	R432030815	R432013413	R432013414
3	1	Rod Cartridge Kit	R432015242	R432015242	R432015242	R432015245	R432015245
4	1	Retaining Ring, Rod Bearing	Repair kit includes ref. numbers 3, 4, 5 & 6	Repair kit includes ref. numbers 3, 4, 5 & 6	Repair kit includes ref. numbers 3, 4, 5 & 6	Repair kit includes ref. numbers 3, 4, 5 & 6	Repair kit includes ref. numbers 3, 4, 5 & 6
5	1	Rod Bearing					
6	1	Rod Wiper					
7	1	Rod Seal					
7	2	Cushion Kit	R432009056	R432015238	R432015238	R432015240	R432015240
8	2	Piston & Tube Seal Kit	R432015250	R432015256	R432015263	R432015269	R432015279
9	1	Tube Seal O'ring	Repair kit includes ref. numbers 8, 9, 10 & 11	Repair kit includes ref. numbers 8, 9, 10 & 11	Repair kit includes ref. numbers 8, 9, 10 & 11	Repair kit includes ref. numbers 8, 9, 10 & 11	Repair kit includes ref. numbers 8, 9, 10 & 11
10	2	Piston Rod Seal					
11	1	Piston Seal					
11	1	Piston Wear Ring					
12	1	Piston	R432013860	R432013861	R432013862	R432013863	R432013864
13	2	Follower, Piston	R432012506	R432012505	R432012507	R432013281	R432013365
14	1	Retaining Nut, Piston Rod	R432013404	R432013404	R432013404	R432013405	R432013405
15	1	Piston Rod, Male 1/2"-20 Thread	various	various	various	-	-
		7/8"-14" Thread	-	-	-	various	various
15a	1	Piston Rod, Female 7/16"-20 Thread	various	various	various	-	-
		3/4"-16 Thread	-	-	-	various	various
16	1	Male Stud (use with ref. 15a) 7/16"-20 Thread	-	-	-	-	-
		3/4"-16 Thread	-	-	-	R433013685	R433013685
17	1	Tube, Body	various	various	various	various	various
18	1	Cap (w/needle valve assembly)	R432030818	R432030819	R432030820	R432012409	R432012410
19	4	Screw, Cap	R432015528	R432015530	R432015530	R432015532	R432015532

\*Order repair parts for double rod cylinders by description and complete cylinder number. See page 44 for assembly drawing.

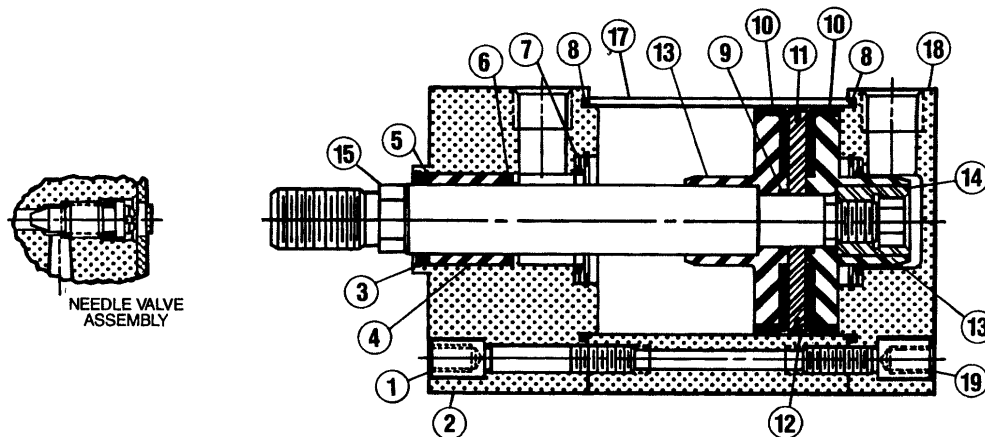

SINGLE ROD MODEL ★

## 1-1/2" - 4" BORE MAJOR REPAIR, MAINTENANCE & TESTING

### MAJOR REPAIR & MAINTENANCE INSTRUCTION

When it is determined that the cylinder requires shop repairs (see GENERAL MAINTENANCE AND REPAIR RECOMMENDATIONS), the following general instructions are recommended.

### DISASSEMBLY, CLEANING & LUBRICATION

Follow warnings on page 36. Disconnect air lines from head and cap ports of cylinder. Completely disassemble the cylinder using the assembly views as reference. No special tools are required except internal snap ring pliers and hex wrench set to remove retaining rings, retaining nut, head & cap screws. A 5/32 socket wrench is required to remove needle valve retainer plate (present on older models).

1. Remove head & cap screws.
2. Remove head & cap.
3. Remove piston rod assembly. To disassemble piston rod, clamp piston rod across flats in soft jaws to remove piston retaining nut. Retaining nut is retained to piston rod with LOCTITE R/C 35.
4. Remove internal retaining rings to remove rod cartridge and cushion kits from head and cap.
5. Remove hex head screws and retainer plate to remove needle valve assembly.

Wash all metal parts in a nonflammable solvent. Rinse each part thoroughly and blow dry with a low pressure air jet. Arrange the parts on a clean surface. Examine each part carefully. Replace all rubber parts and all other worn or damaged parts. The use of REPAIR KITS is strongly recommended.

### REASSEMBLY

The procedure for reassembly is essentially the reverse of disassembly. However, the following exceptions should be noted:

1. All O-rings should be well coated with Cylinder Lube grease as they are installed in their respective grooves and prior to reassembly with the mating part. (**NOTE:** For FOOD SERVICE USE, use NORDSTROM Grease; see page 37.) Care must be taken when assembling O-rings and packings that they are not damaged, as this will cause leakage.
2. Assemble the piston followers, piston, and piston seals to the piston rod less lubricant. The piston retaining nut should be assembled with LOCTITE retaining compound R/C 35 and torqued as shown on torque specification chart with the piston rod clamped in soft jaws.
3. Reassemble the cylinder using the assembly views as reference. Pay particular attention to the installation of the cushion kit (ref. 7) to insure that the tapered rubber surface marked "THIS SIDE UP" faces to the inside (piston side) of the cylinder. As the assembly proceeds, lubricate the piston seals, cushion seals, rod seal, tube, and the tube seals with Cylinder Lube grease.
4. Torque head and cap screws to torque specification shown on chart.

### TESTING

After the cylinder has been completely reassembled, it should be tested, either on a test bench or in the regular installation.

### TEST PROCEDURE

The cylinder should be tested for cushioning, travel and leakage.

#### A. CUSHIONING

1. Turn both cushioning screws clockwise all the way in.
2. Cycle cylinder a few times by alternating supply pressure to head and cap ports.
3. Apply supply pressure to the head port. Rod should retract, decelerate and may stop before completion of stroke.
4. Apply supply pressure to the cap port. Rod should extend, decelerate and may stop before completion of stroke.

#### B. TRAVEL AND LEAKAGE

1. Turn the cushioning screws counterclockwise one (1) full turn.
2. Apply supply pressure to the head port. Cylinder should have less cushioning and make full stroke + or -.062". Check leakage at cap port, 30cc/min. leakage permitted. Check leakage around rod seal. No leakage permitted.
3. Apply supply pressure to the cap port. Cylinder should have less cushioning and make full stroke + or -.062". Check leakage at head port. 30cc/min. leakage permitted.
4. Return piston rod to retract position by applying supply pressure to head port. Remove supply pressure and install cylinder in service if satisfactory.

### CUSHION ADJUSTMENT

Turn the needle valve clockwise to increase the amount of cushioning and counter clockwise to decrease cushioning. To obtain the most effective cushioning, final adjustment must be made while the cylinder is operating under normal conditions at normal operating pressure.

### TORQUE SPECIFICATIONS (foot pounds)

Piston Rod Nut:	
Rod Diameter 5/8"	10 Loctite R/C 277
Rod Diameters 1" & 1-3/8"	45 Loctite R/C 277

Head & Cap Screws:	
Bores 1-1/2" - 2-1/2"	8 Non-Lubricated
Bores 3-1/4" - 4"	10 Non-Lubricated

# Taskmaster® Pneumatic Cylinder

Installation and Service Information



## 5" & 6" Bore Size Basic Cylinder Parts List & Assembly Drawing

### Basic MS4 Parts List - Single Rod Model\*

Ref.	Qty.	Description	Part Number by Bore Size			
			5" Bore		6" Bore	
			1" Rod	1-3/8" Rod	1-3/8" Rod	1-3/4" Rod
1	8	Nut, Tie Rod Lock	R431001891	R431001891	R431001891	R431001891
2	4	Tie Rod	various	various	various	various
3	1	Head (w/needle valve assembly)	R432014644	R432014644	R432014648	R432014648
4	1	Rod Bearing and Housing	R432014625	R432014629	R432014636	R432014640
4a	1	Housing, Rod Bearing	R432014602	R432014603	R432014604	R432014605
4b	1	Retaining Ring, Housing	R432012240	R432012240	R432012241	R432012241
4c	1	Washer, Retaining Housing	R432012259	-	R432012260	-
4d	1	Rod Cartridge Kit	R432014626	R432014630	R432014637	R432014641
		Bearing, Rod	Repair kit	Repair kit	Repair kit	Repair kit
4e	1	Seal, Rod	includes	includes	includes	includes
4f	1	Wiper, Rod	ref. numbers	ref. numbers	ref. numbers	ref. numbers
4g	1	Seal, Housing O-ring	4d,4e,4f & 4g	4d,4e,4f & 4g	4d,4e,4f & 4g	4d,4e,4f & 4g
5	2	Cushion Kit	R432014608	R432014608	R432014610	R432014610
6	1	Piston Assembly Kit, Complete	R432014612	R432014612	R432014618	R432014618
6a	1	Nut, Piston Retaining	Kit incl. ref.	Kit incl. ref.	Kit incl. ref.	Kit incl. ref.
6b	2	Piston, Half	6a thru 6f	6a thru 6f	6a thru 6f	6a thru 6f
6c	1	Piston & Tube Seal Kit	R432014614	R432014614	R432014620	R432014620
		Rod Seal, Piston O-ring	Repair kit	Repair kit	Repair kit	Repair kit
6d	2	Piston Seal	includes	includes	includes	includes
6e	1	Piston Wear Ring	ref. numbers	ref. numbers	ref. numbers	ref. numbers
6f	2	Tube Seal, O-ring	6c,6d,6e & 6f	6c,6d,6e & 6f	6c,6d,6e & 6f	6c,6d,6e & 6f
7	1	Piston Rod Male				
		3/4"-16 Thread	various	-	-	-
		7/8"-14 Thread	various	-	-	-
		1"-14 Thread	-	various	various	-
		1 1/4"-12 Thread	-	various	various	various
		1 1/2"-12 Thread	-	-	-	various
7a	1	Piston Rod Female				
		3/4"-16 Thread	various	-	-	-
		1"-14 Thread	-	various	various	-
		1 1/4"-12 Thread	-	-	-	various
8	1	Tube	various	various	various	various
9	1	Cap (w/needle valve assembly)	R432014646	R432014646	R432014650	R432014650

\*Order repair parts for double rod cylinders by description and complete cylinder number. See page 44 for assembly drawing.

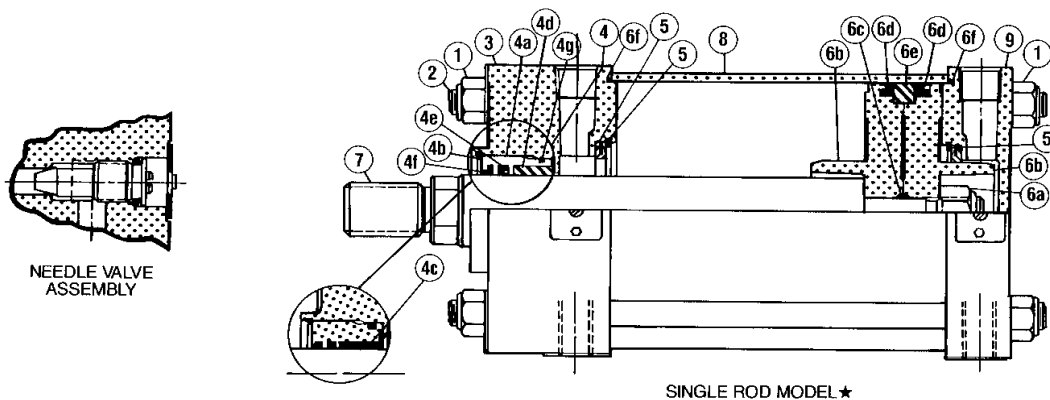

### 5" - 6" BORE MAJOR REPAIR, MAINTENANCE & TESTING

#### MAJOR REPAIR AND MAINTENANCE INSTRUCTION

When it is determined that the cylinder requires shop repairs (see GENERAL MAINTENANCE AND REPAIR RECOMMENDATIONS), the following general instructions are recommended.

#### DISASSEMBLY, CLEANING AND LUBRICATION

Follow warnings on page 36. Disconnect air lines from head and cap ports of cylinder.

Completely disassemble the cylinder using the assembly views as reference. No special tools are required except internal snap ring pliers to remove retaining rings. A 5/32 internal socket wrench is required to remove the needle valve retainer plate (present on older models).

1. Remove the tie rod nuts and tie rods.
2. Remove head and cap.
3. Remove piston rod assembly. To disassemble piston rod, clamp piston rod across flats in soft jaws before removing piston retaining nut. Retaining nut is torqued to piston rod.
4. Remove internal retaining rings in head and cap assemblies to remove the rod bearing cartridge and cushion kits.
5. Remove two hex head screws and retainer plate to remove valve assembly.

Wash all metal parts in a nonflammable solvent. Rinse each part thoroughly and blow dry with a low pressure air jet. Arrange the parts on a clean surface. Examine each part carefully. Replace all rubber parts and all other worn or damaged parts. The use of REPAIR KITS is strongly recommended.

#### REASSEMBLY

The procedure for reassembly is essentially the reverse of disassembly. However, the following exceptions should be noted.

1. All O-rings should be well coated with Cylinder Lube grease as they are installed in their respective grooves and prior to reassembly with the mating part. (**NOTE:** For FOOD SERVICE USE, use NORDSTROM Grease; see page 37.) Care must be taken when assembling O-rings and packings that they are not damaged, as this will cause leakage.
2. Assemble the teflon wear ring, piston rod seal and piston follower on the piston rod. The wear ring and piston seals should be assembled less lubricant. The piston retaining nut should be assembled lubricated and torqued as shown on specification chart with piston rod clamped across flats in soft jaws.

3. Reassemble the cylinder using the assembly views as reference. Pay particular attention to the installation of the cushion kit (ref. 5) to insure that the tapered rubber surface marked "THIS SIDE UP" faces to the inside (piston side) of the cylinder. As the assembly proceeds, lubricate the piston seals, cushion seals, tube seals and tube with Cylinder Lube grease.
4. Tie rod threads should be well lubricated to allow tightening the nuts evenly for proper pre-stressing. To avoid twisting of the tie rods during tightening, hold with vise grip or clamp. To assure equal pre-stressing of the tie rods, first turn on nuts even and snug to align assembly, then the nuts are to be tightened alternately. For proper tie rod pre-stressing, they should be torqued as recommended.

#### TESTING

After the cylinder has been completely reassembled, it should be tested either on a test bench or in the regular installation.

#### TEST PROCEDURE

The cylinder should be tested for cushioning, travel and leakage.

##### A. CUSHIONING

1. Turn both cushioning screws clockwise all the way in.
2. Cycle cylinder a few times by alternating supply pressure to head and cap ports.
3. Apply supply pressure to the head port. Rod should retract, decelerate and may stop before completion of stroke.
4. Apply supply pressure to the cap port. Rod should extend, decelerate and may stop before completion of stroke.

##### B. TRAVEL AND LEAKAGE

1. Turn the cushioning screws counterclockwise one (1) full turn.
2. Apply supply pressure to the head port. Cylinder should have less cushioning and make full stroke + or -.062". Check leakage at cap port, 30cc/min. leakage permitted. Check leakage around rod seal. No leakage permitted.
3. Apply supply pressure to the cap port. Cylinder should have less cushioning and make full stroke + or -.062". Check leakage at head port. 30cc/min. leakage permitted.
4. Return piston rod to retract position by applying supply pressure to head port. Remove supply pressure and install cylinder in service if satisfactory.

#### TORQUE SPECIFICATIONS

CYL. BORE	ROD DIA.	TORQUE (FOOT POUNDS)	
		PISTON ROD NUT	TIE ROD NUT
5"	1", 1-3/8"	60 Lubricated	30 Lubricated
6"	1-3/8", 1-3/4"	120 Lubricated	30 Lubricated

## Assembly Drawings for Double Rod Models

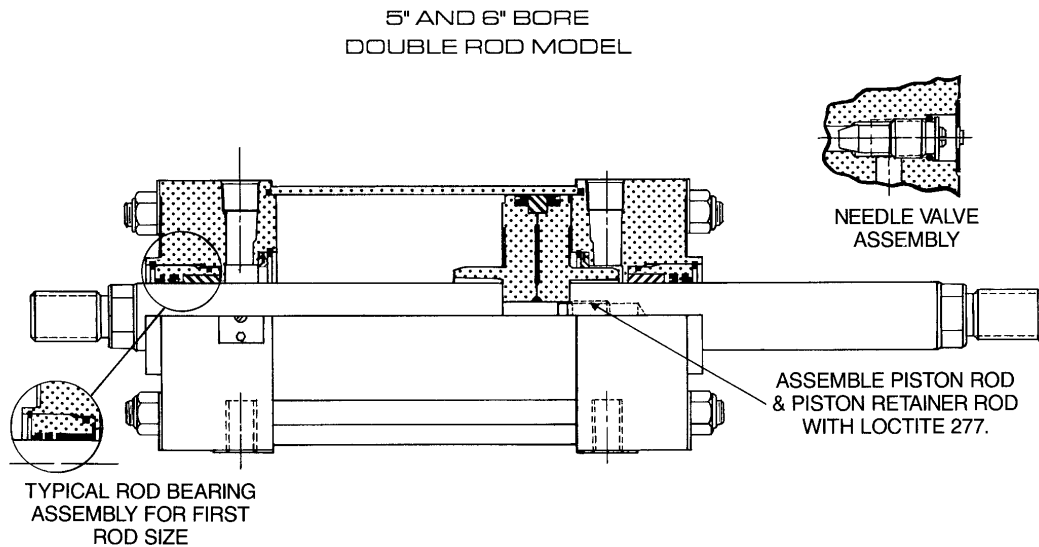
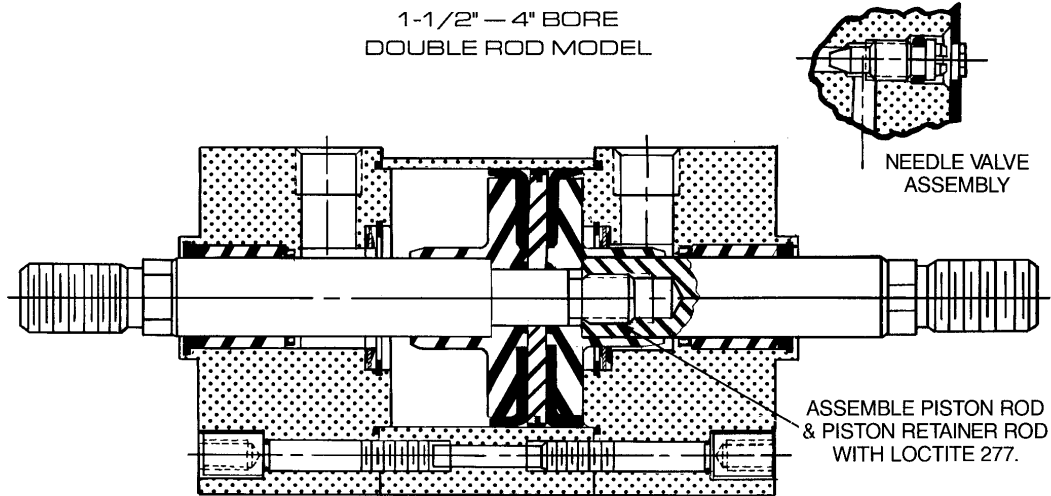

# Taskmaster® Pneumatic Cylinder

## Pneumatic Timing Volumes



### Pneumatic Timing Volumes

AVENTICS offers a wide range of timing volumes for a variety of pneumatic system uses. These volumes are rated at 200 psi (13.8 bar) maximum working pressure with a 5 to 1 safety factor. They are constructed of lightweight, corrosion resistant anodized aluminum ends and tubing. Each end has two threaded mounting holes.

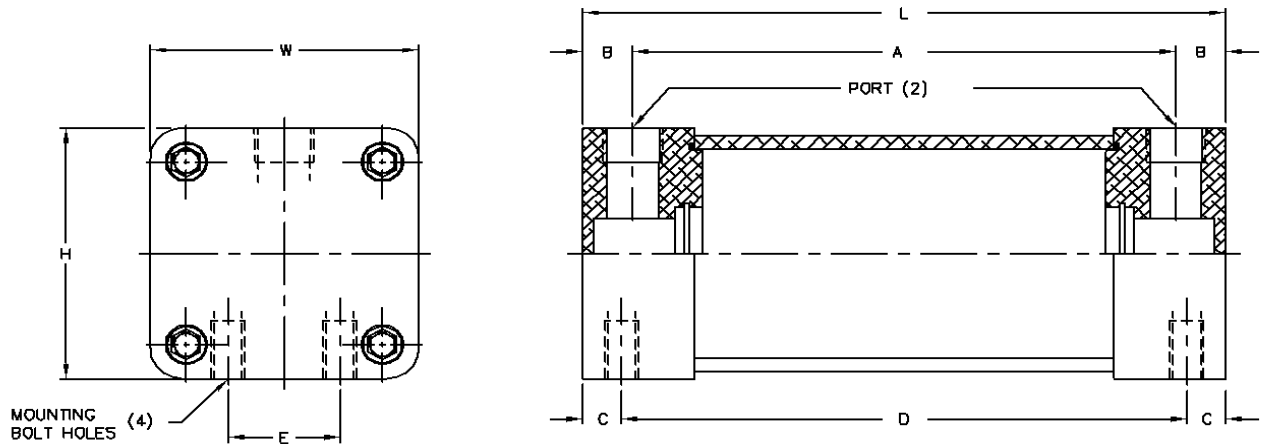

Volume Capacity Cu. Inch*	Overall Size			Dimensions (Ports)			Mounting Holes				Part Number	Weight (lbs.)
	H	W	L	Thread*	A	B	Thread	C	D	E		
5	2	2	5-5/16	1/4-18	4-3/16	9/16	1/4-20	7/16	4-7/16	5/8	R432013441	1.0
8	2	2	7-1/16	1/4-18	5-15/16	9/16	1/4-20	7/16	6-3/16	5/8	R432013442	1.3
8	3	3	4-5/16	1/4-18	3-3/16	9/16	3/8-16	7/16	3-7/16	1-1/4	R434002910	1.8
12	2	2	9-5/16	1/4-18	8-3/16	9/16	1/4-20	7/16	8-7/16	5/8	R432013443	1.5
12	3	3	5-3/16	1/4-18	4-1/16	9/16	3/8-16	7/16	4-5/16	1-1/4	R434002897	2.0
20	2	2	13-13/16	1/4-18	12-11/16	9/16	1/4-20	7/16	12-15/16	5/8	R432013444	2.0
20	3	3	6-13/16	1/4-18	5-11/16	9/16	3/8-16	7/16	5-15/16	1-1/4	R434002896	2.3
20	4-1/2	4-1/2	4-1/8	3/8-18	3-1/8	1/2	1/2-13	9/16	3	2-1/16	R434002906	3.8
30	3	3	8-13/16	1/4-18	7-11/16	9/16	3/8-16	7/16	7-15/16	1-1/4	R434002895	2.6
30	4-1/2	4-1/2	4-7/8	3/8-18	3-7/8	1/2	1/2-13	9/16	3-3/4	2-1/16	R434002905	4.1
45	3	3	11-15/16	1/4-18	10-13/16	9/16	3/8-16	7/16	11-1/16	1-1/4	R434002894	3.2
45	4-1/2	4-1/2	6-1/8	3/8-18	5-1/8	9/16	1/2-13	9/16	5	2-1/16	R434002904	4.7
60	4-1/2	4-1/2	7-3/8	3/8-18	6-3/8	1/2	1/2-13	9/16	6-1/4	2-1/16	R434004028	5.2
80	4-1/2	4-1/2	8-7/8	3/8-18	7-7/8	1/2	1/2-13	9/16	8-1/8	2-1/16	R434002903	5.8
100	4-1/2	4-1/2	10-1/2	3/8-18	9-1/2	1/2	1/2-13	9/16	9-3/8	2-1/16	R434002902	6.6
225	4-1/2	4-1/2	20-1/2	3/8-18	19-1/2	1/2	1/2-13	9/16	19-1/4	2-1/16	R434002899	10.9

\*NPTF ports

Dimensions in inches.

Other sizes available, contact factory.



# NOTICE TO PRODUCT USERS

## 1. WARNING: FLUID MEDIA

AVENTICS pneumatic devices are designed and tested for use with filtered, clean, dry, chemical free air at pressures and temperatures within the specified limits of the device. For use with media other than air or for human life support systems, AVENTICS must be consulted. Hydraulic cylinders are designed for operation with filtered, clean, petroleum based hydraulic fluid; operation using fire-resistant or other special types of fluids may require special packing and seals. Consult the factory.

## 2. WARNING: MATERIAL COMPATIBILITY

Damage to product seals or other parts caused by the use of non-compatible lubricants, oil additives or synthetic lubricants in the air system compressor or line lubrication devices voids the AVENTICS warranty and can result in product failure or other malfunction. See lubrication recommendations below.

**AIR LINE LUBRICANTS!** In service higher than 18 cycles per minute or with continuous flow of air through the device, an air line lubricator is recommended.\* (Do not use line lubrication with vacuum products.) However, the lubricator must be maintained since the oil will wash out the grease, and lack of lubrication will greatly shorten the life expectancy. The oils used in the lubricator must be compatible with the elastomers in the device. The elastomers are normally BUNA-N, NEOPRENE, VITON, SILICONE and HYTREL. AVENTICS recommends the use of only petroleum based oils without synthetic additives, and with an aniline point between 180° F and 210° F.

**COMPRESSOR LUBRICANTS!** All compressors (with the exception of special "oil free" units) pass oil mist or vapor from the internal crankcase lubricating system through to the compressed air. Since even small amounts of non-compatible lubricants can cause severe seal deterioration (which could result in component and system failure) special care should be taken in selecting compatible compressor lubricants.

## 3. WARNING: INSTALLATION AND MOUNTING

The user of these devices must conform to all applicable electrical, mechanical, piping and other codes in the installation, operation or repair of these devices.

**INSTALLATION !** Do not attempt to install, operate or repair these devices without proper training in the technique of working on pneumatic or hydraulic systems and devices, unless under trained supervision.

Compressed air and hydraulic systems contain high levels of stored energy. Do not attempt to connect, disconnect or repair these products when a system is under pressure. Always exhaust or drain the pressure from a system before performing any service work. Failure to do so can result in serious personal injury.

**MOUNTING!** Devices should be mounted and positioned in such a manner that they cannot be accidentally operated.

## 4. WARNING: APPLICATION AND USE OF PRODUCTS

The possibility does exist for any device or accessory to fail to operate properly through misuse, wear or malfunction. The user must consider these possibilities and should provide appropriate safe guards in the application or system design to prevent personal injury or property damage in the event of a malfunction.

## 5. WARNING: CONVERSION, MAINTENANCE AND REPAIR

When a device is disassembled for conversion to a different configuration, maintenance or repair, the device must be tested for leakage and proper operation after being reassembled and prior to installation.

**MAINTENANCE AND REPAIR!** Maintenance periods should be scheduled in accordance with frequency of use and working conditions. All AVENTICS products should provide a minimum of 1,000,000 cycles of maintenance free service when used and lubricated as recommended. However, these products should be visually inspected for defects and given an "in system" operating performance and leakage test once a year. Where devices require a major repair as a result of the one million cycles, one year, or routine inspection, the device must be disassembled, cleaned, inspected, parts replaced as required, rebuilt and tested for leakage and proper operation prior to installation. See individual catalogs for specific cycle life estimates.

## 6. PRODUCT CHANGES

Product changes including specifications, features, designs and availability are subject to change at any time without notice. For critical dimensions or specifications, contact factory.

\*Many AVENTICS pneumatic valves and cylinders can operate with or without air line lubrication; see individual sales catalogs for details.

-Refer to the appropriate service manual for parts and service information, most are available for download from [www.aventics.com/us](http://www.aventics.com/us)

## LIMITATIONS OF WARRANTIES & REMEDIES

AVENTICS warrants its products sold by it to be free from defects in material and workmanship to the following: For twelve months after shipment AVENTICS will repair or replace (F.O.B. our works), at its option, any equipment which under normal conditions of use and service proves to be defective in material or workmanship at no charge to the purchaser. No charge will be made for labor with respect to defects covered by this Warranty, provided that the work is done by AVENTICS or any of its authorized service facilities. However, this Warranty does not cover expenses incurred in the removal and reinstallation of any product, nor any downtime incurred, whether or not proved defective.

All repairs and replacement parts provided under this Warranty policy will assume the identity, for warranty purposes, of the part replaced, and the warranty on such replacement parts will expire when the warranty on the original part would have expired. Claims must be submitted within thirty days of the failure or be subject to rejection.

This Warranty is not transferable beyond the first using purchaser. Specifically, excluded from this Warranty are failures caused by misuse, neglect, abuse, improper operation or filtration, extreme temperatures, or unauthorized service or parts. This Warranty also excludes the use of lubricants, fluids or air line additives that are not compatible with seals or diaphragms used in the products. This Warranty sets out the purchaser's exclusive remedies with respect to products covered by it, whether for negligence or otherwise. Neither, AVENTICS nor any of its affiliates will be liable for consequential or incidental damages or other losses or expenses incurred by reason of the use or sale of such products. Our liability (except as to title) arising out of the sale, use or operation of any product or parts, whether on warranty, contract or negligence (including claims for consequential or incidental damage) shall not in any event exceed the cost of replacing the defective products and, upon expiration of the warranted period as herein provided, all such liability is terminated. THIS WARRANTY IS IN LIEU OF ALL OTHER WARRANTIES, EXPRESS OR IMPLIED, WHETHER FOR MERCHANTABILITY OR FITNESS FOR A PARTICULAR PURPOSE OR OTHERWISE. No attempt to alter, amend or extend this Warranty shall be effective unless authorized in writing by an officer of AVENTICS Corporation.

AVENTICS reserves the right to discontinue manufacture of any product, or change product materials, design or specifications without notice.

**AVENTICS Corporation**

1953 Mercer Road  
Lexington, KY 40514  
Tel 859.254.8031  
Fax 800.489.1488  
[www.aventics.com/us](http://www.aventics.com/us)  
[info.us@aventics.com](mailto:info.us@aventics.com)



**AVENTICS Incorporated**

5515 North Service Rd  
Suite #100  
Burlington, Ontario L7L 6A6  
Tel 905.332.0399  
Fax 905.332.8596  
[www.aventics.com/ca](http://www.aventics.com/ca)  
[info.ca@aventics.com](mailto:info.ca@aventics.com)

Further contacts:

[www.aventics.com/en/contact](http://www.aventics.com/en/contact)

The data specified only serve to describe the product. No statements concerning a certain condition or suitability for a certain application can be derived from our information. The information given does not release the user from the obligation of own judgment and verification. It must be remembered that our products are subject to a natural process of wear and aging.